

Desarrollos únicos que son tendencia



la actualización 20/03/2026



FRENTE INTEGRAL
MANUAL TÉCNICO















(0351)695 7920

aluwind.com.ar



[f](#) [@](#) [v](#) AluwindSA

Av. Japón 550 - Córdoba, Argentina











CÓDIGO	DESCRIPCIÓN	PESO Kg/m	FORMA	L. Std.
AW 5374	Columna simple	1,150		6,03
AW 5378	Tapa columna simple	0,357		6,03
AW 5379	Soporte tapa	0,412		6,03
AW 2776	Columna 100 mm	1,675		6,03
AW 7696	Columna 120 mm	2,049		6,03
AW 7697	Columna 170 mm	3,149		6,03
AW 800	Marco para ventana desplazable	0,888		6,03
AW 5261	Hoja de ventana desplazable	0,557		6,03
AW 832	Columna de esquina a 90°	2,468		6,03
AW 997	Adaptador DVH	0,503		6,03
AW 833	Escuadra Frente Integral	1,769		6,03
AW 834	Soporte frente a losa	2,119		6,03

FRENTE INTEGRAL **SLIM 45**

AW 5474	Columna 60 mm	1,236		6,03
AW 5476	Columna 100 mm	1,554		6,03

*L. Std: Largo Standard

CÓDIGO	DESCRIPCIÓN	PESO Kg/m	FORMA	L. Std.
AW 5478	Tapa	0,317		6,03
AW 5479	Soporte de tapa	0,342		6,03
AW 5997	Adaptador DVH	0,388		6,03
AW 5995	Soporte Frente a Losa	1,998		6,03
AW 5996	Escuadra SLIM45	1,558		6,03
AW 5480	Columna de esquina a 90°	2,161		6,03
AW 5481	Refuerzo Interno	1,458		6,03
AW 5482	Refuerzo Interno	1,889		6,03

*L. Std: Largo Standard

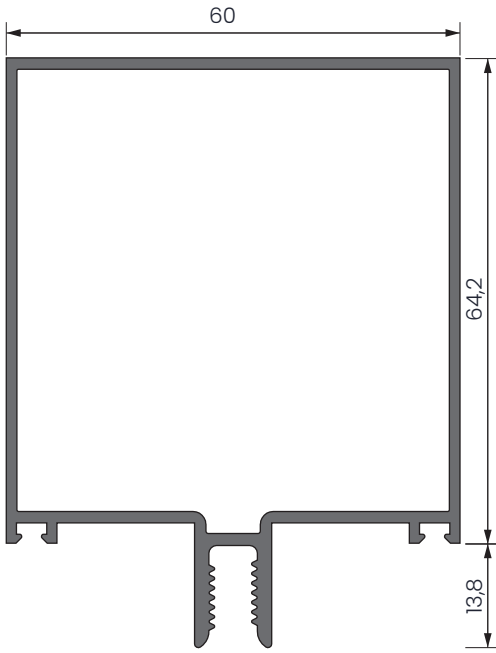

AW 5374

Columna de 60 mm.
1.150Kg/m. Largo 6,03m

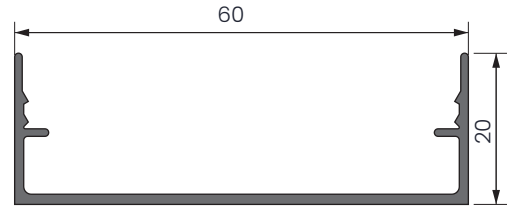

AW 5378

Tapa de columna.
0,357Kg/m. Largo 6,03m

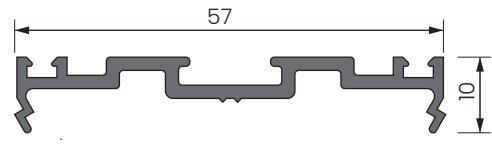

AW 5379

Prensa de tapa. 0,412 Kg/m.
Largo 6,03m

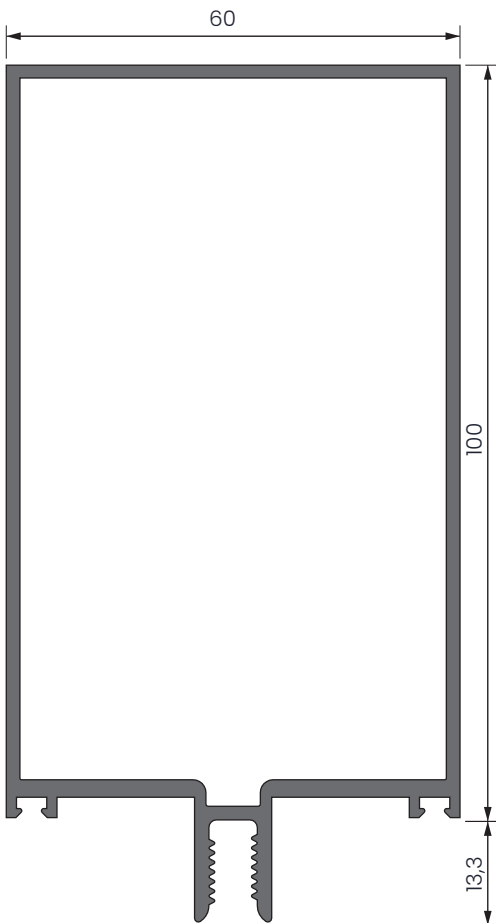

AW 2776

Columna de 100 mm.
1.675 Kg/m. Largo 6,03m

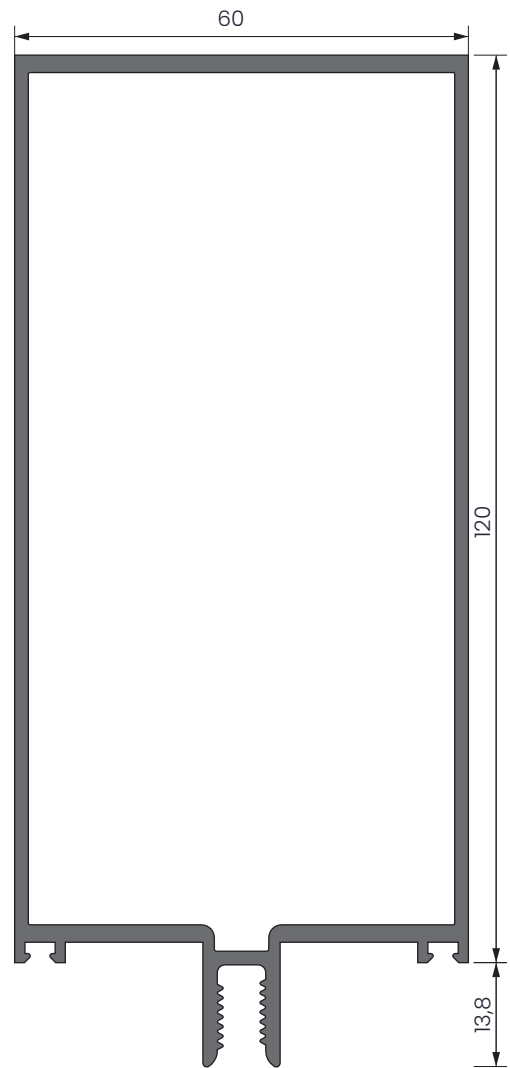

AW 7696

Columna de 120 mm.
2,049 Kg/m. Largo 6,03m

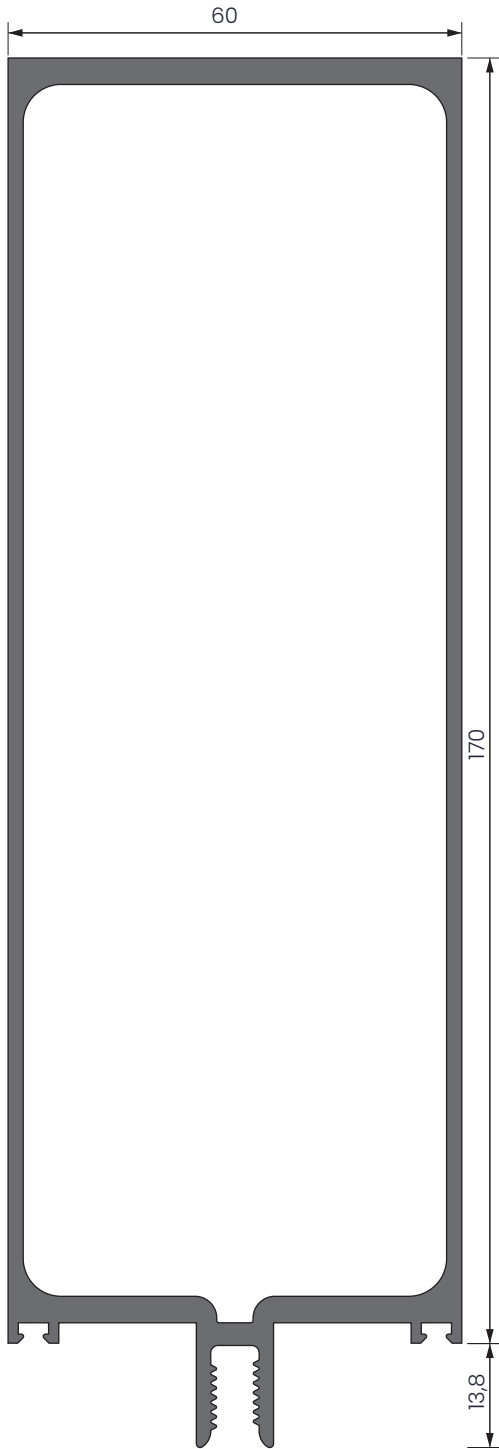

AW 7697

Columna de 170 mm.
3,149 Kg/m. Largo 6,03m

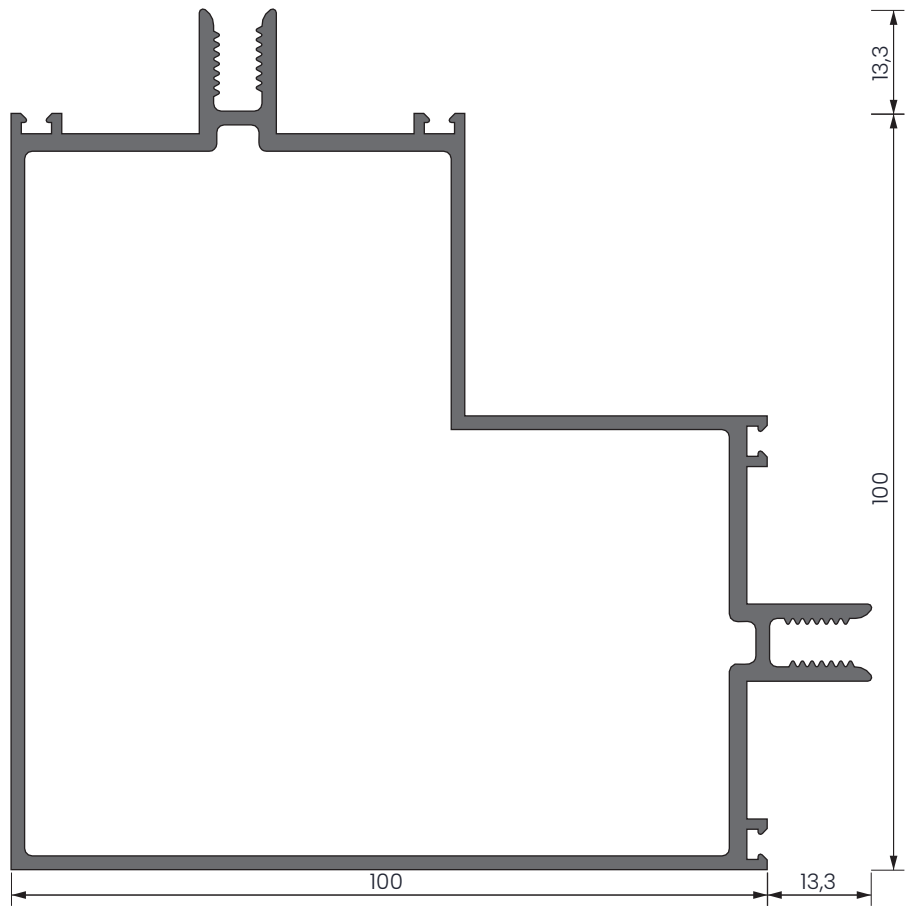

AW 832

Columna de esquina a a 90°.
2,468Kg/m. Largo 6,03m

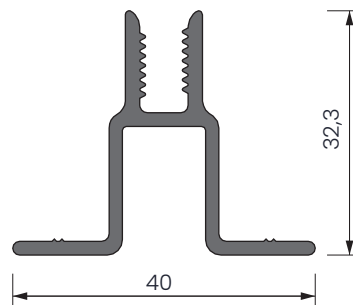

AW 997

Adaptador PARA DVH.
0,503Kg/m. Largo 6,03m

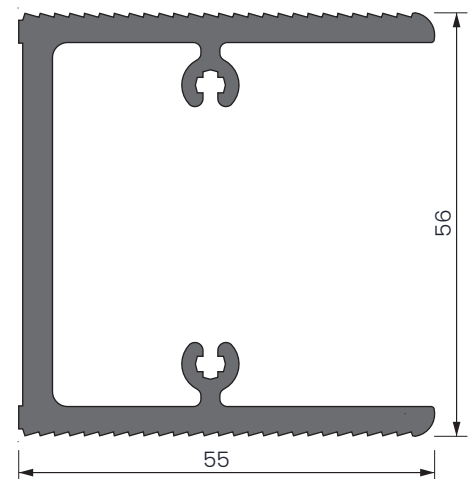

AW 833

Escuadra . 1,769Kg/m.
Largo 6,03m

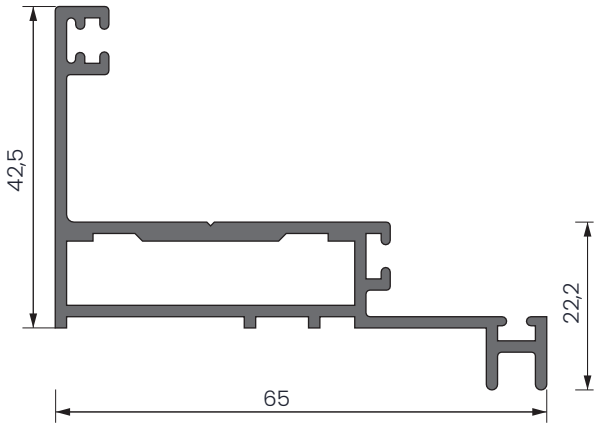

AW 800

Marco para ventana deslizable
0,888Kg/m. Largo 6,03m

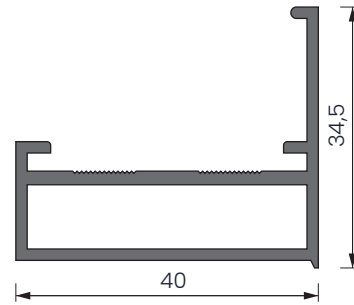

AW 5261

Hoja de ventana deslizable
0,557Kg/m. Largo 6,03m

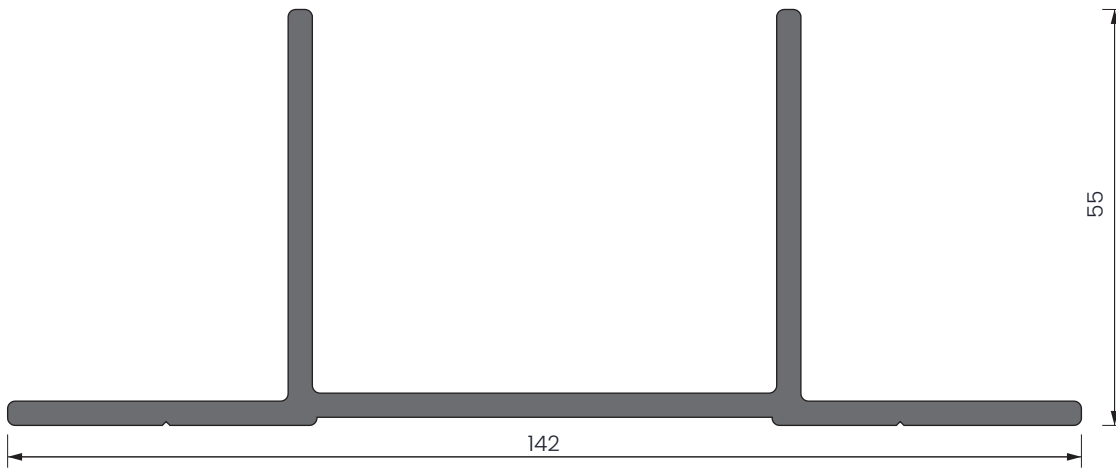

AW 834

Soporte frente a losa.
2,119Kg/m. Largo 6,03m

ACRISTALAMIENTO

Cubierta mecánica del borde M y la holgura del borde AA para varios espesores de vidrio con el panel mas grueso E

*Dimensiones expresadas en milímetros (mm).

L: lado mas largo del panel de vidrio	E < 6		6 < E ≤ 8		8 < E ≤ 12		12 < E ≤ 15		15 < E ≤ 25	
	M	A-A	M	A-A	M	A-A	M	A-A	M	A-A
L = 1 m	6	3	6	3	7	3	7	4	8	4
1 m < L = 2 m	7	4	7	4	8	4	8	4	10	4
2 m < L = 4,5 m	10	5	10	5	11	5	11	5	12	5
4,5 m < L = 6 m	10	6	10	6	11	6	11	6	12	6

*En paneles mayores a 6 revisar los cálculos con ingeniero.

*Los valores de holgura del corte A-A consideran las tolerancias del corte del vidrio.

* La tabla no aplica para instalaciones de vidrios inclinados.

*Cuando la hoja que contiene al vidrio está perforada para drenajes, la holgura del borde A-A debe ser mayor a 6mm.

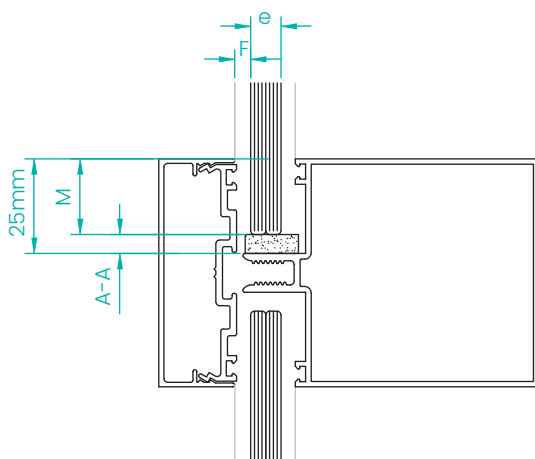

VIDRIO SIMPLE

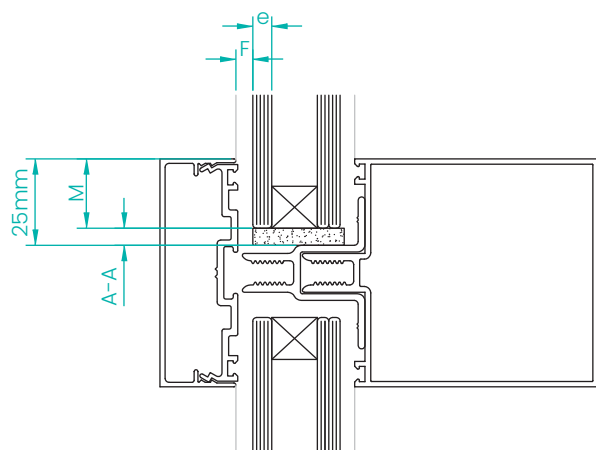

DOBLE VIDRIADO HERMETICO

ACCESORIOS STANDARD

DESCRIPCION	APLICACION	IMAGEN
<p>Anclaje para frente a losa</p> <p>FI01</p>		<p>ALUWIND PEDIDOS WEB!</p>
<p>Burlete separador de columna COD. B58</p>		
<p>Burlete de acristalamiento COD. B37</p>		
<p>Bulón rosca w 1/4"</p>		
<p>Escuadra de armado</p> <p>FI02 Para columna de 60mm (AW 5374).</p> <p>FI03 Para columna de 100mm (AW 2776).</p> <p>FI04 Para columna de 120mm (AW 7696).</p> <p>FI05 Para columna de 170mm (AW 7697).</p>		<p>ALUWIND PEDIDOS WEB!</p>

DESCUENTOS

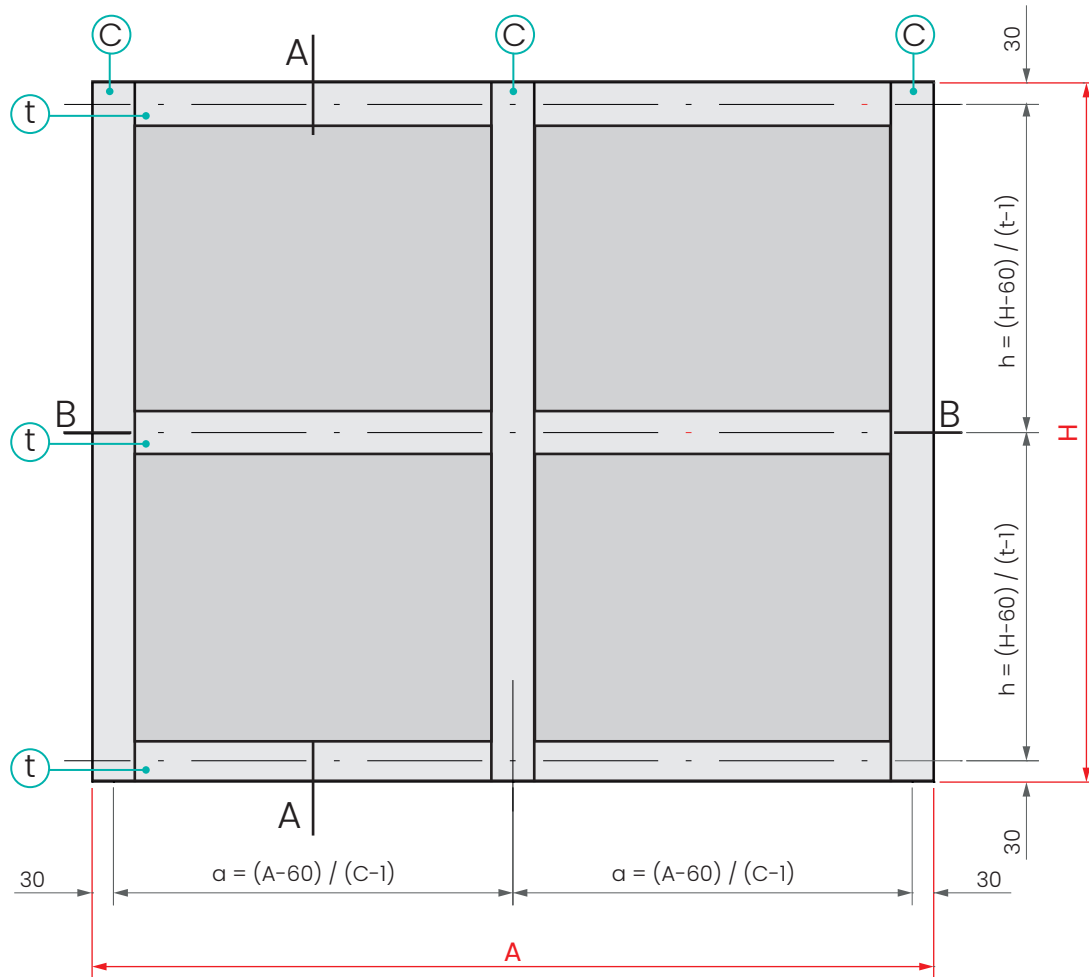

C = Cantidad de columnas

t = Cantidad de ejes horizontales

Descuentos en perfiles

CANT.	PERFIL	MEDIDA	DESCRIPCIÓN	CORTE
C	AW 5374 AW 2776 AW 7696 AW 7697	H	Columna de frente integral	90-90
(C-1) x t	AW 5374 AW 2776 AW 7696 AW 7697	a - 60	Travesaño de frente integral	90-90
N	AW 997	H	Adaptador para DVH	90-90
(C-1) x t	AW 997	a - 60	Adaptador para DVH	90-90
(C-1) x t	AW 5379	a - 60	Prensa de tapa	90-90
C x (t-1)	AW 5379	h - 5	Prensa de tapa	90-90
(C-1) x t	AW 5378	a - 60	Tapa	90-90
C	AW 5378	H	Tapa	90-90

CORTE A-A

t = Cantidad de ejes horizontales

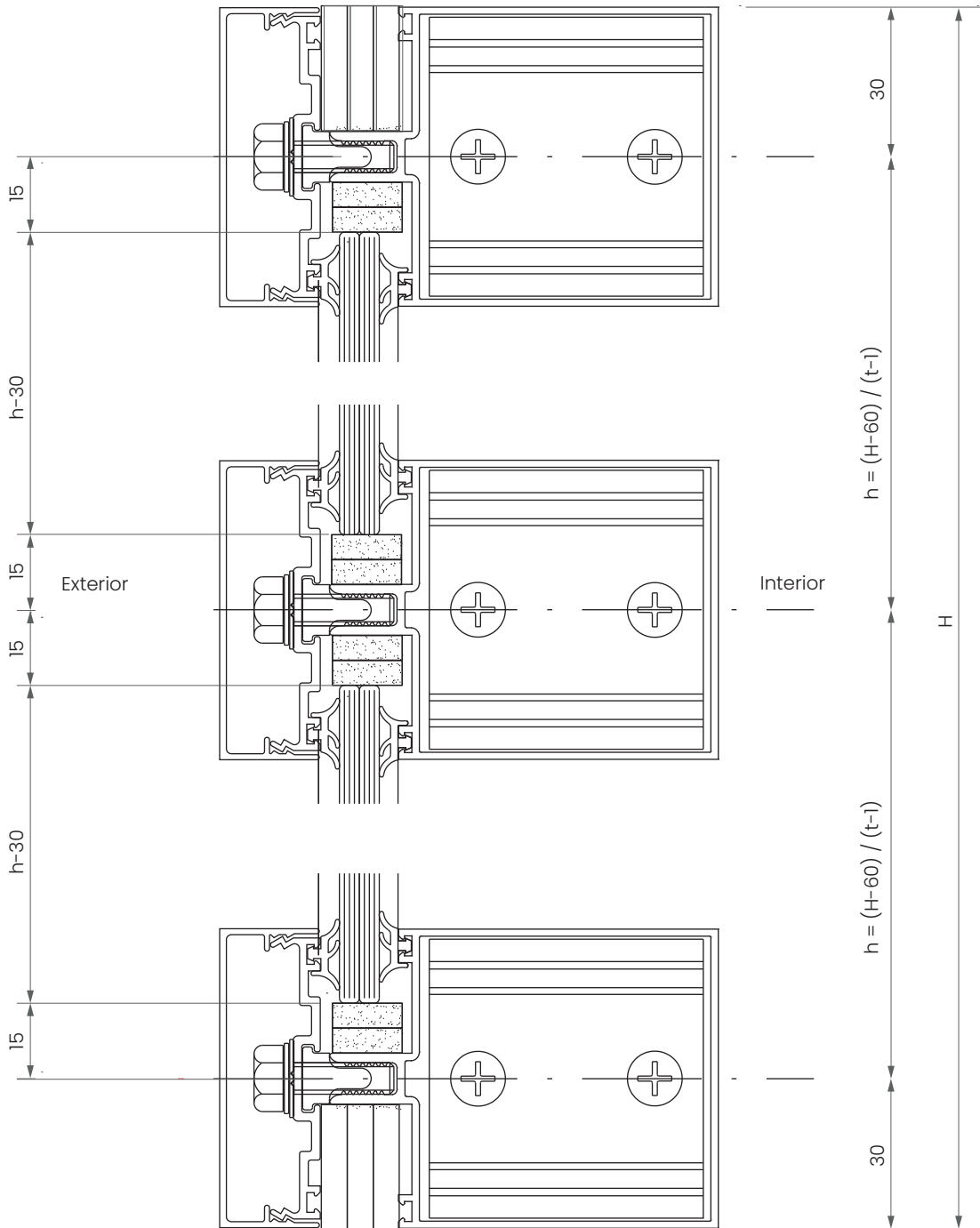

CORTE B-B

C = Cantidad de columnas

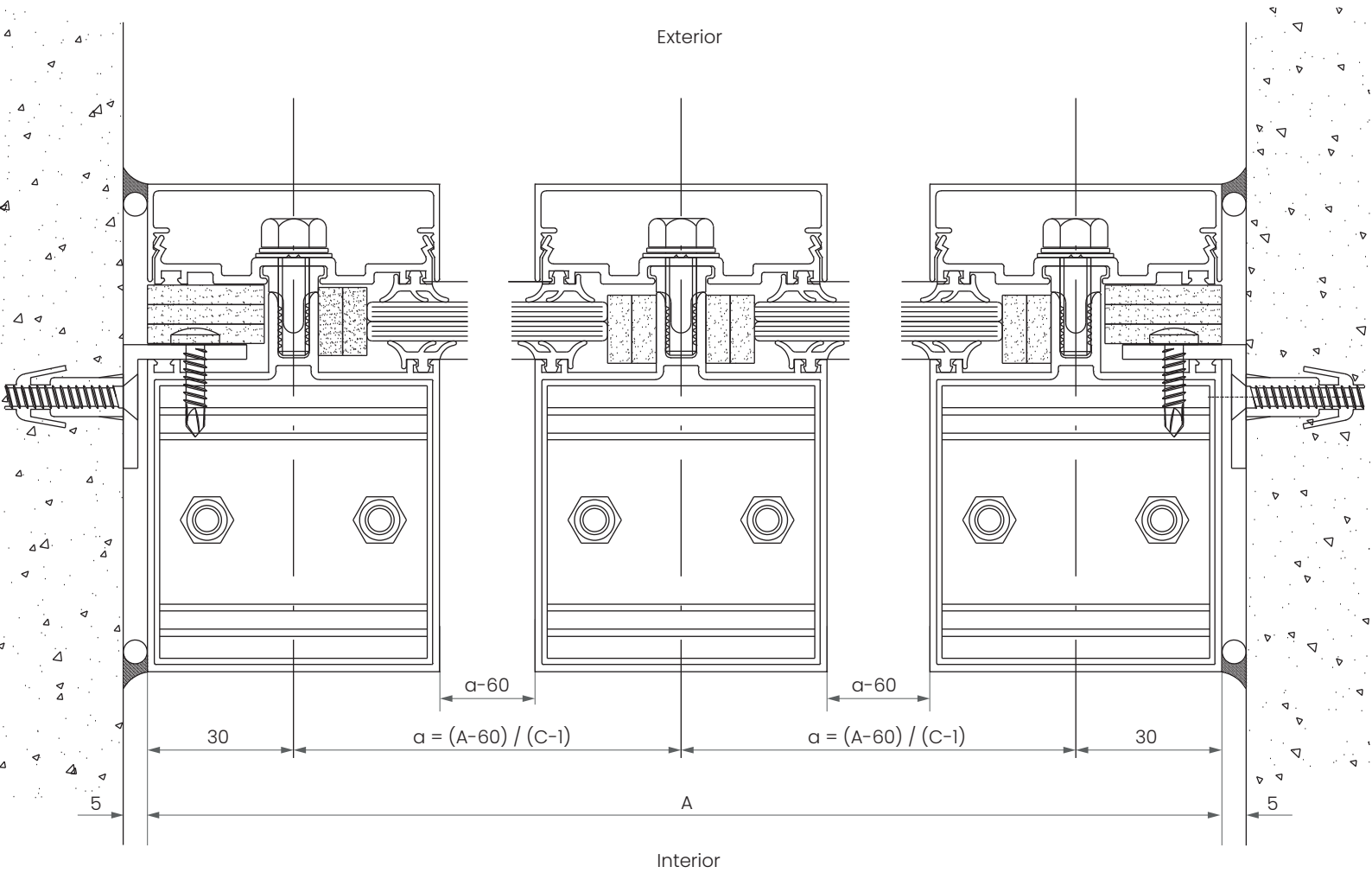

Detalle Vidrio simple

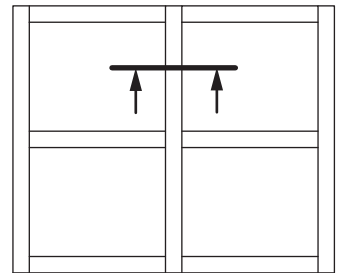
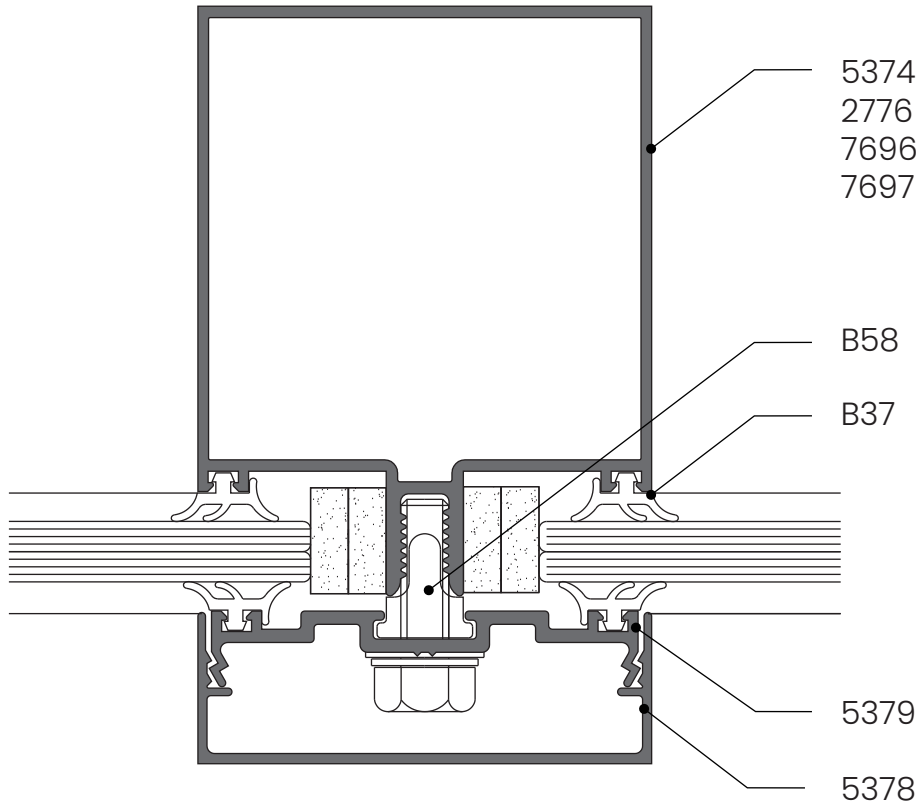

Detalle DVH

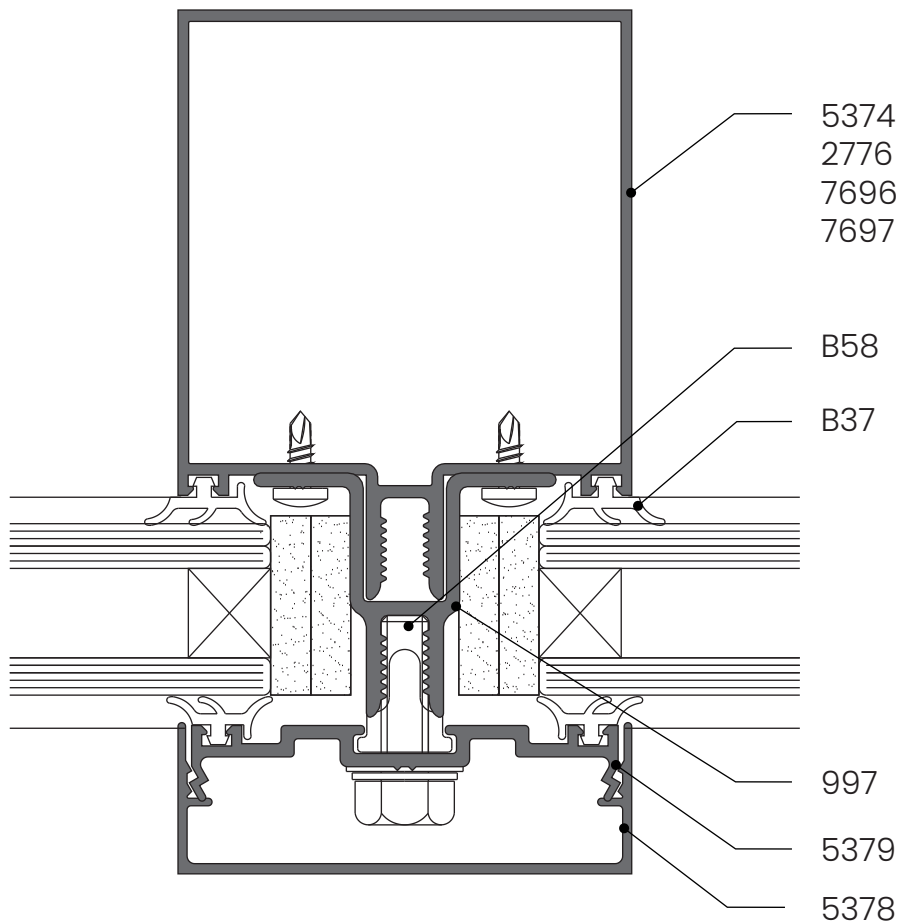

Detalle cierre con columna

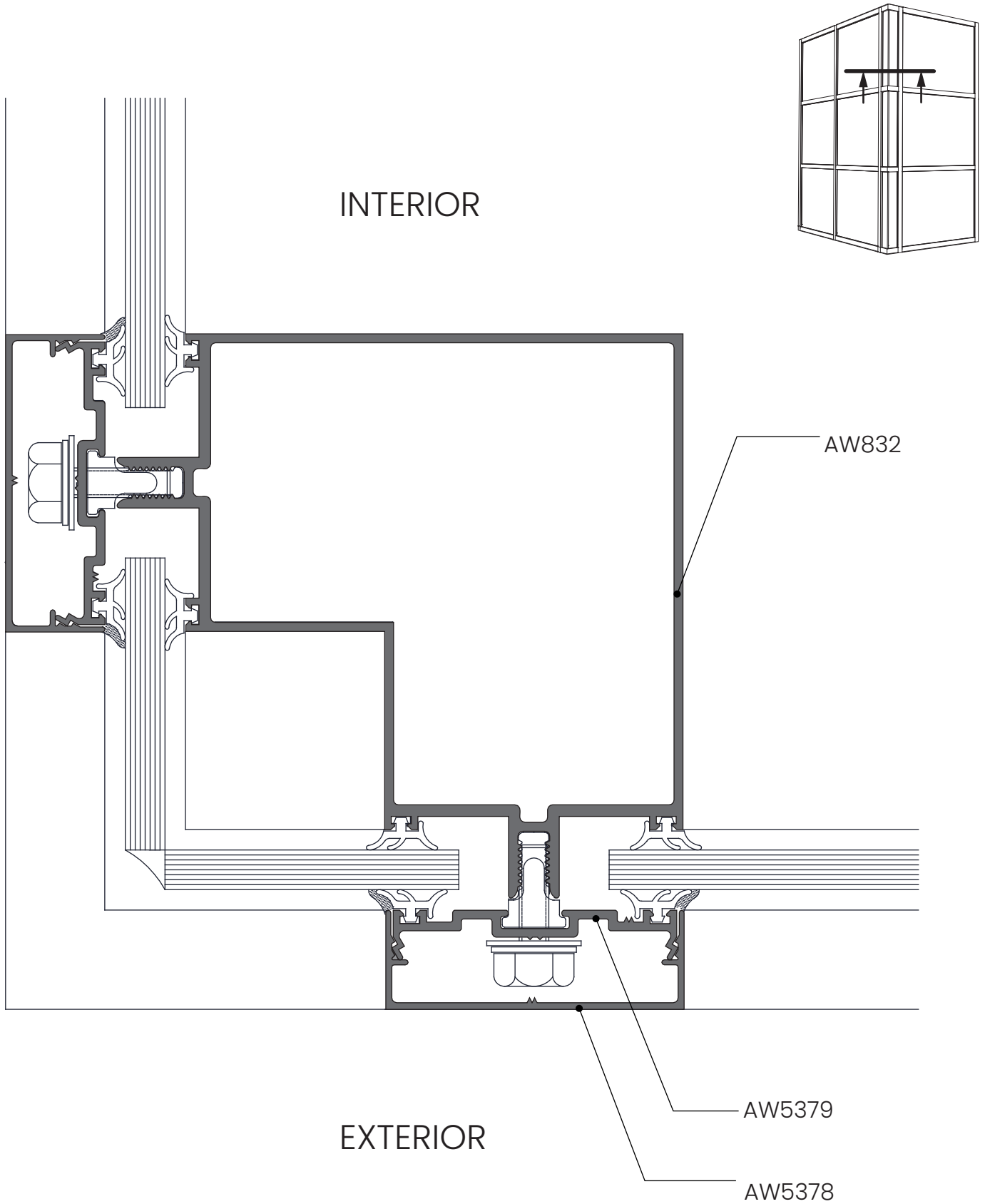

Detalle con ventana desplazable

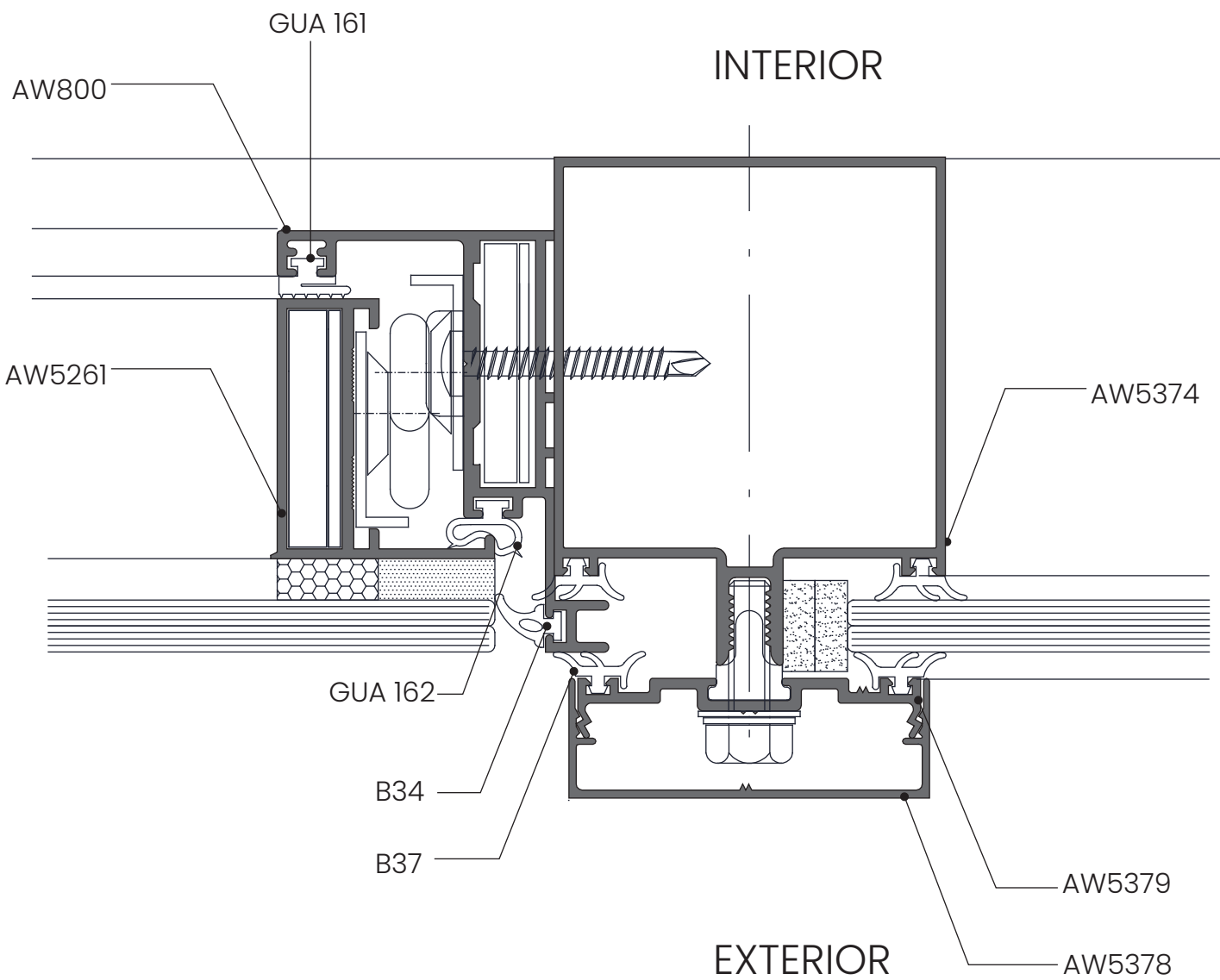
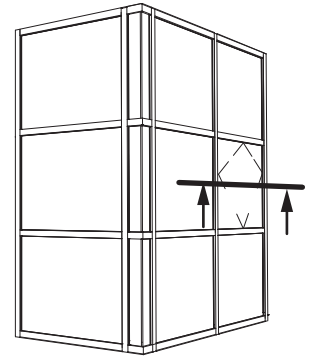

Detalle con soporte frente a losa FI01

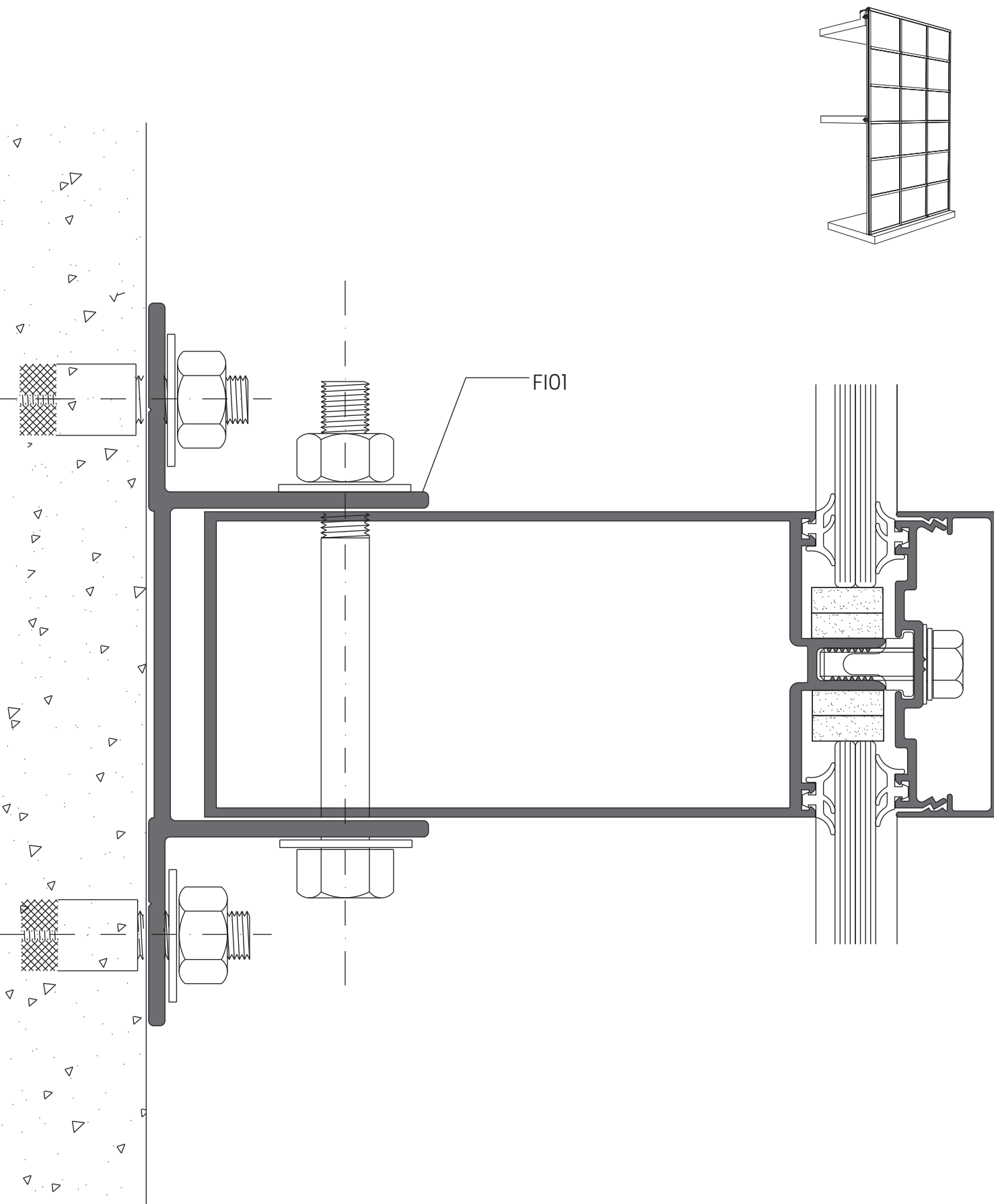

Detalle de sujecion con FI02

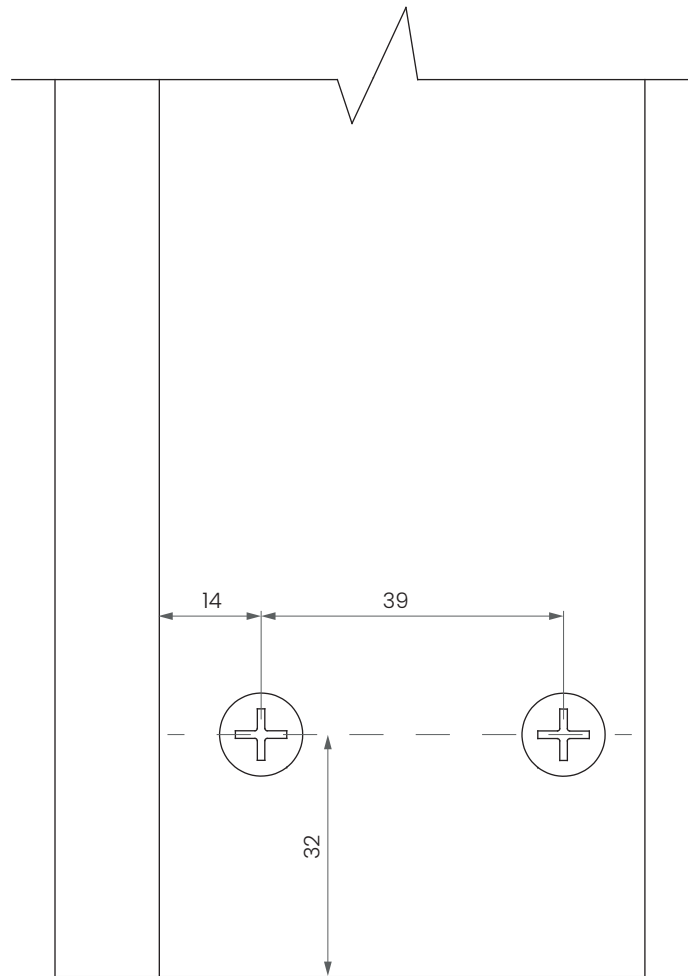
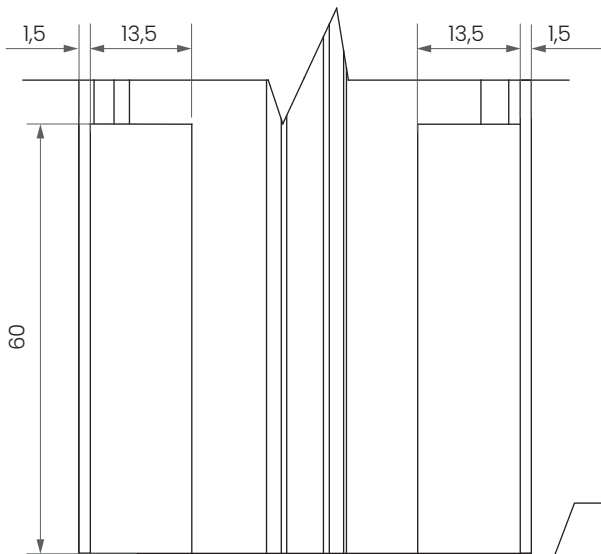
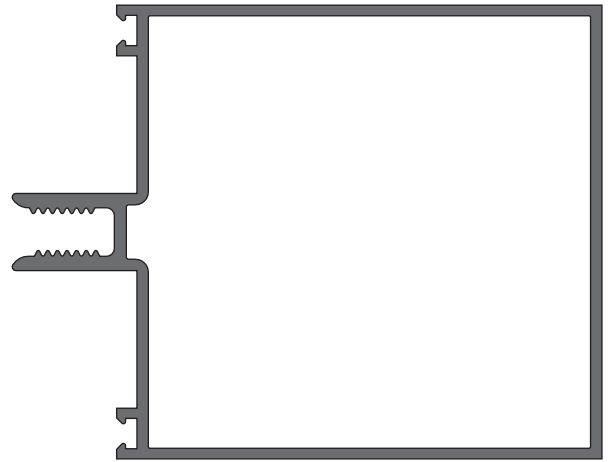
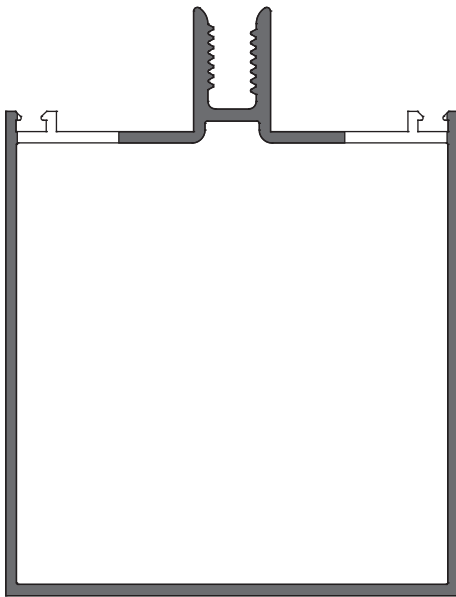

FI02

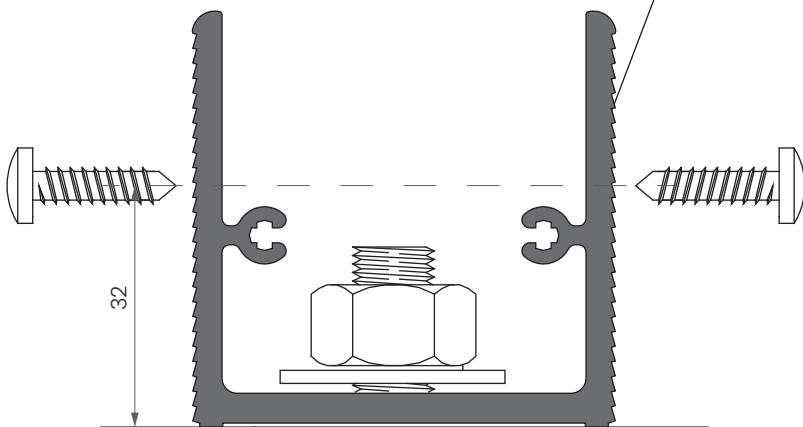

32

Broca con prisionero
diametro 9,5 x 80 mm
con tuerca y arandela
de acero inoxidable
cincado

ESQUEMA DE ARMADO

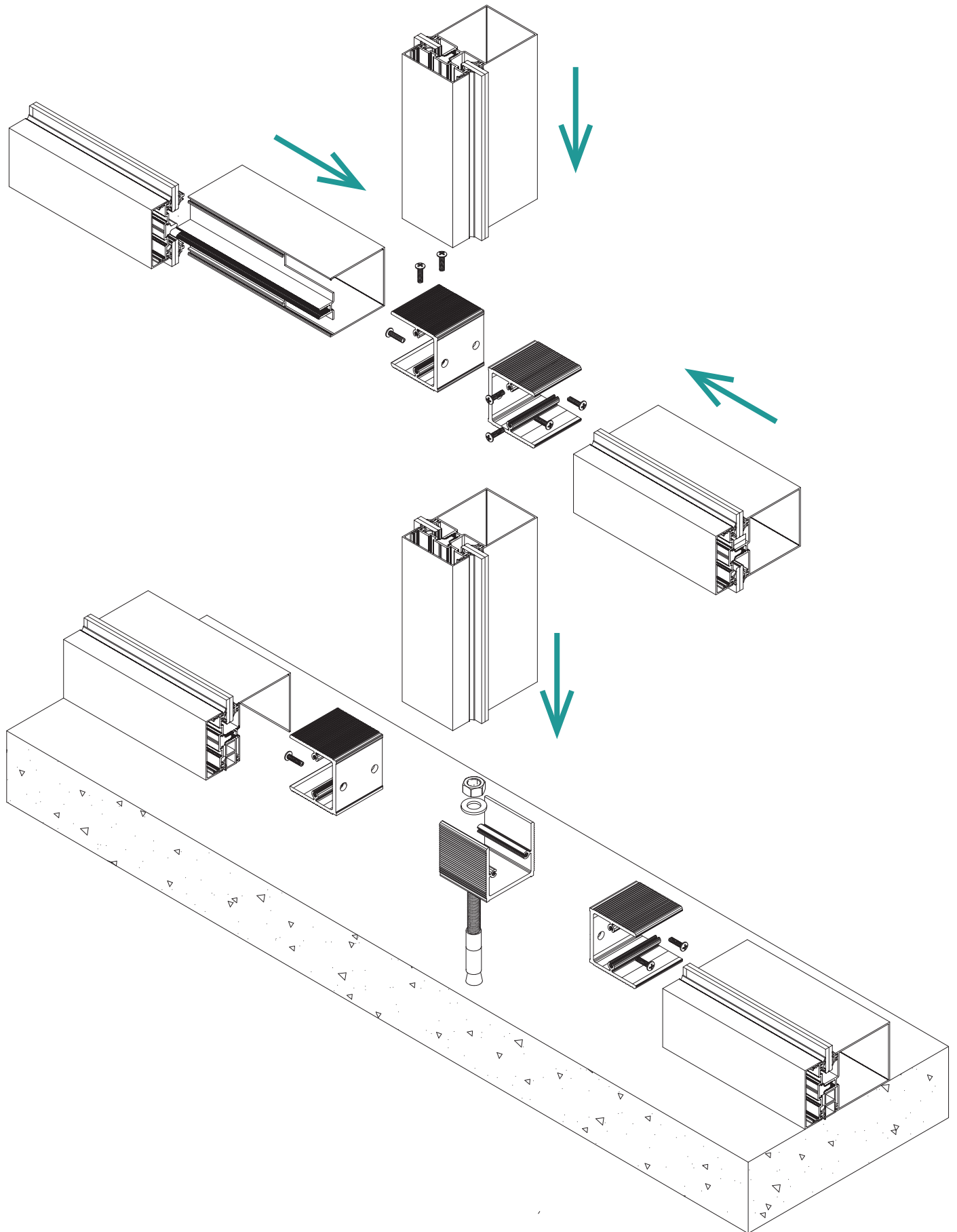

Limites dimensionales

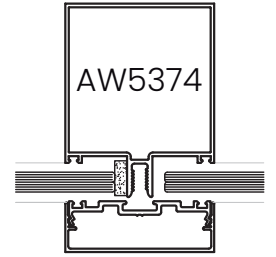
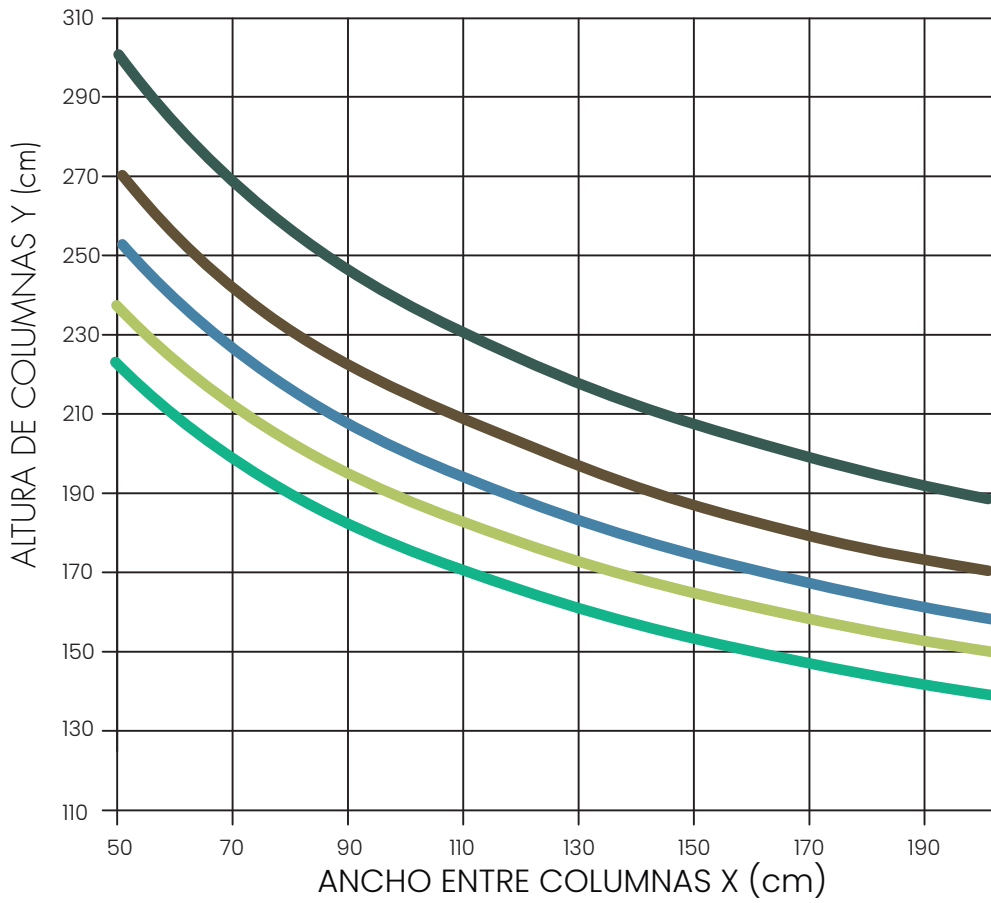

- 60 Kg/m²
- 80 Kg/m²
- 100 Kg/m²
- 120 Kg/m²
- 150 Kg/m²

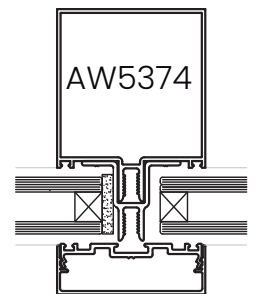
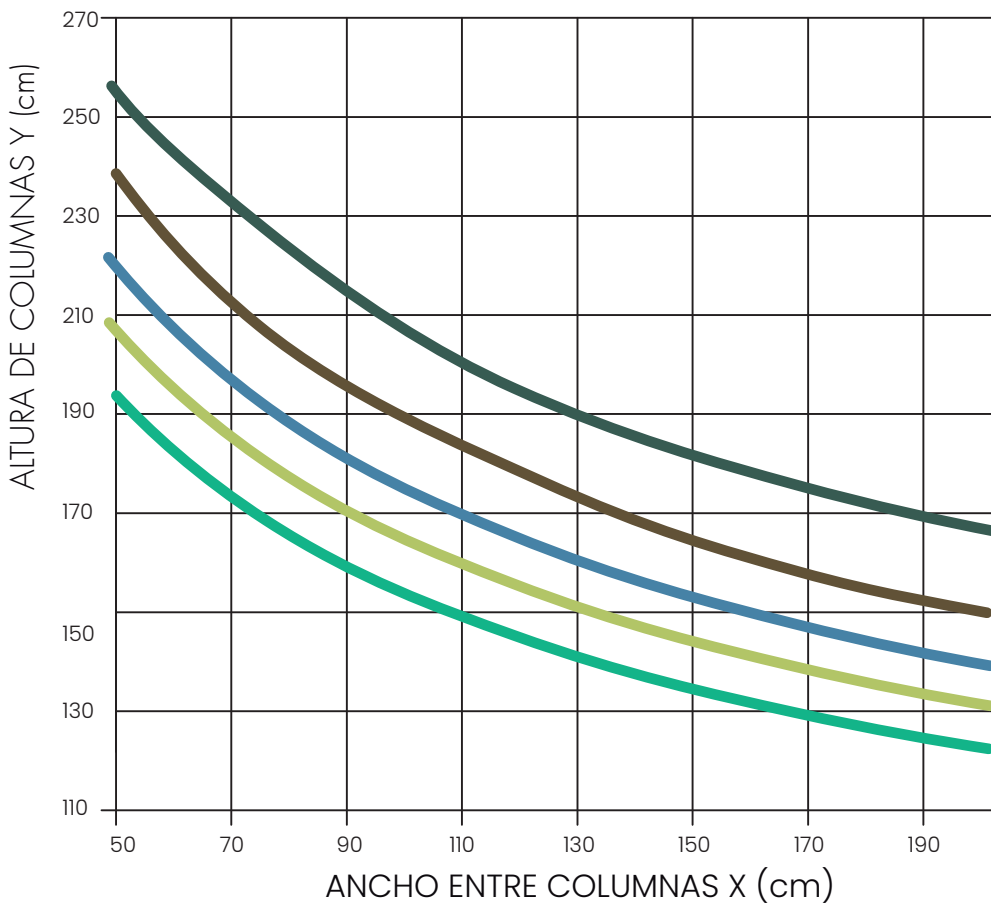
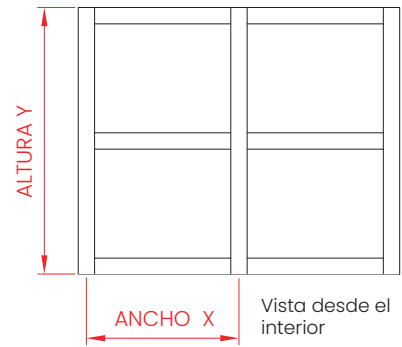

- 60 Kg/m²
- 80 Kg/m²
- 100 Kg/m²
- 120 Kg/m²
- 150 Kg/m²

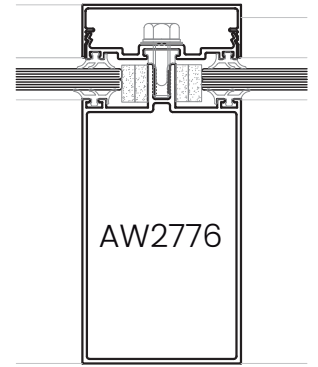
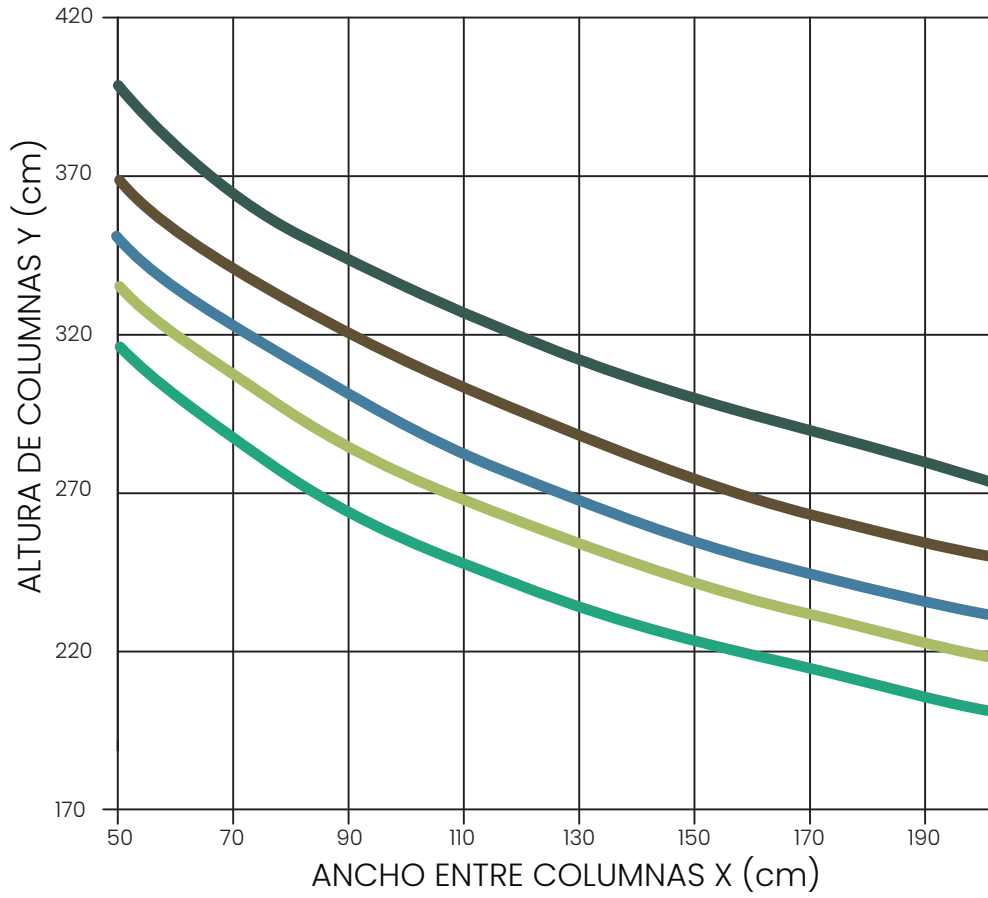

- 60 Kg/m²
- 80 Kg/m²
- 100 Kg/m²
- 120 Kg/m²
- 150 Kg/m²

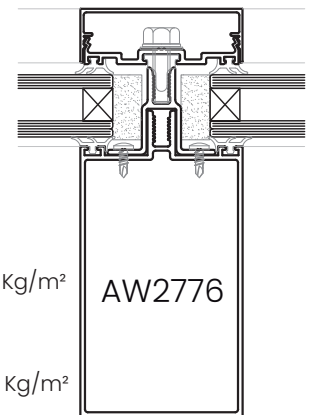
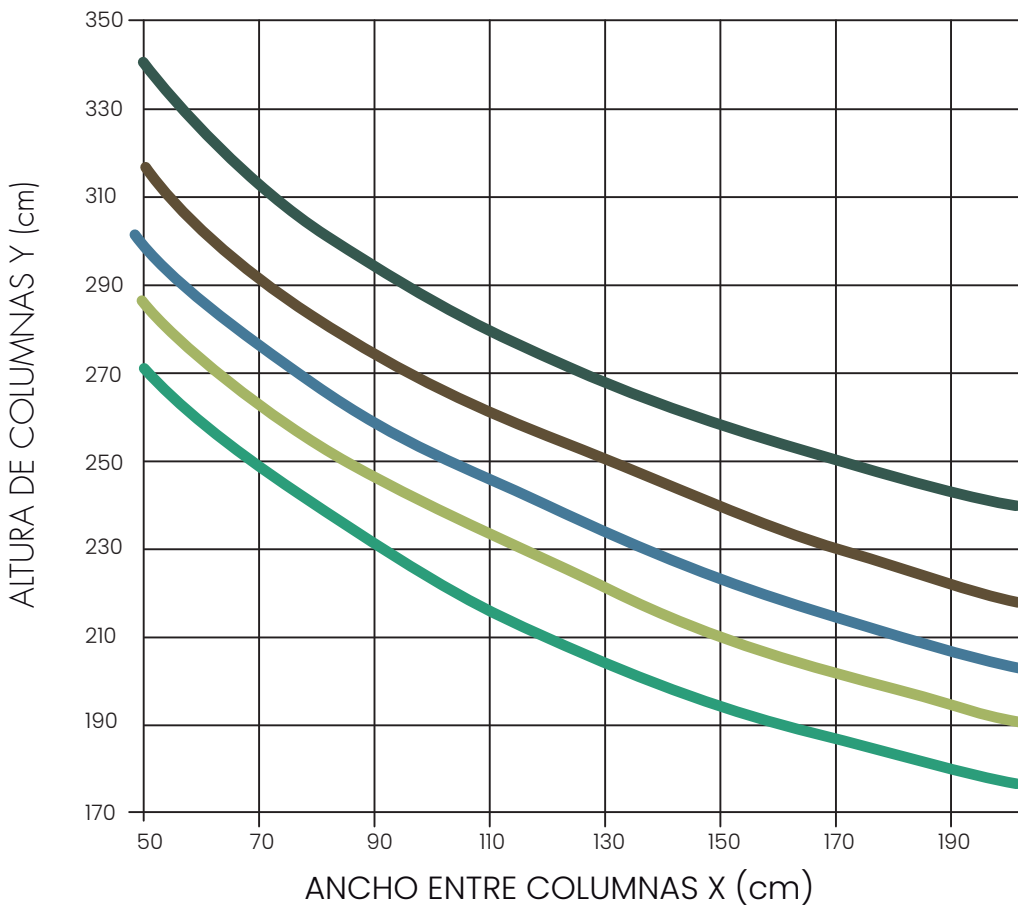
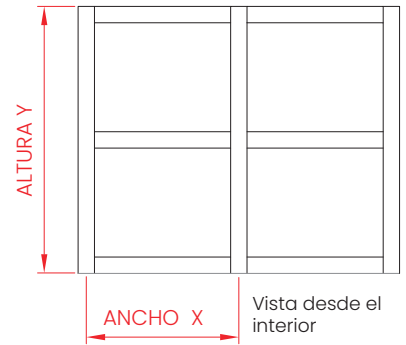

- 60 Kg/m²
- 80 Kg/m²
- 100 Kg/m²
- 120 Kg/m²
- 150 Kg/m²

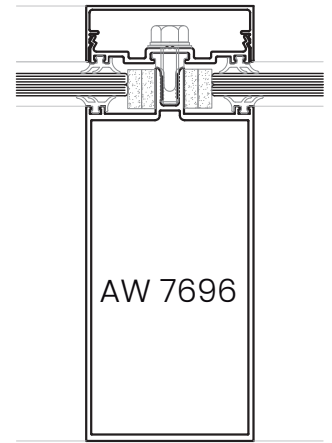
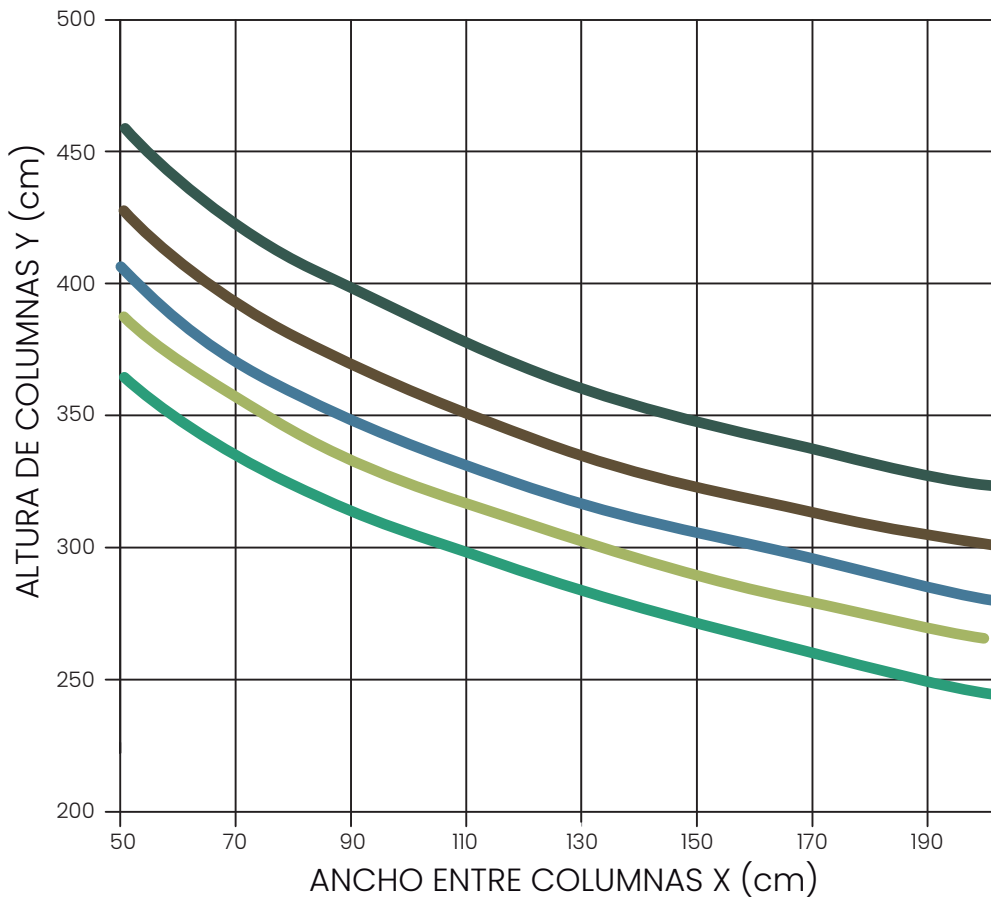

- 60 Kg/m²
- 80 Kg/m²
- 100 Kg/m²
- 120 Kg/m²
- 150 Kg/m²

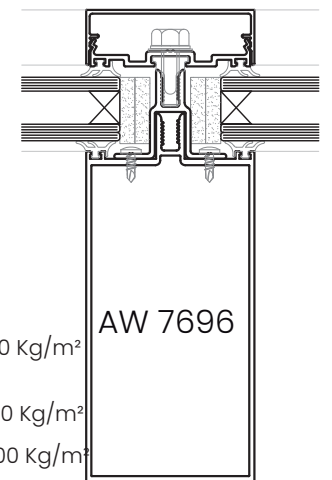
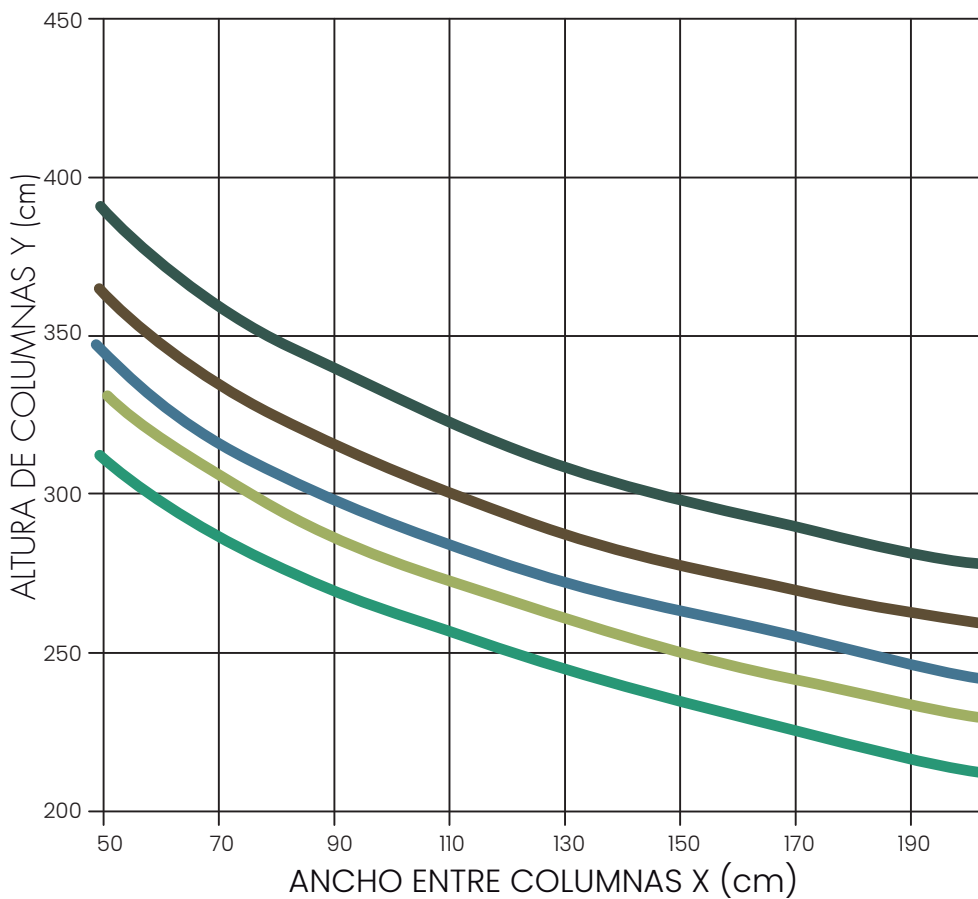
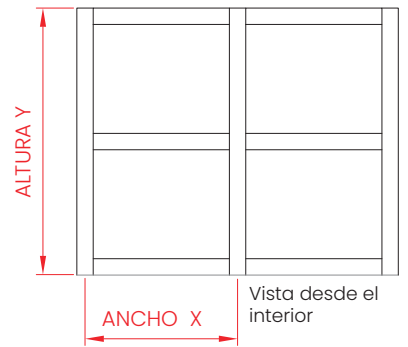

- 60 Kg/m²
- 80 Kg/m²
- 100 Kg/m²
- 120 Kg/m²
- 150 Kg/m²

SLIM 45

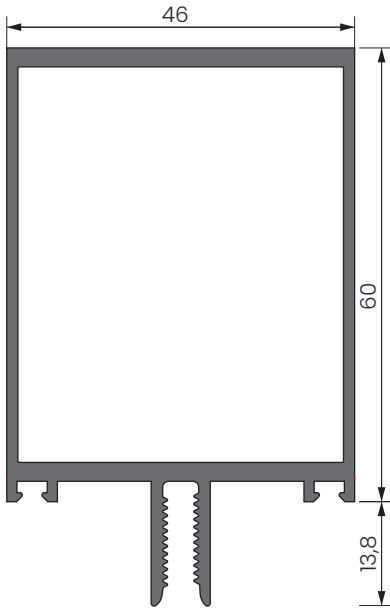

AW 5474

Columna de 60mm
1,236Kg/m. Largo 6,03m

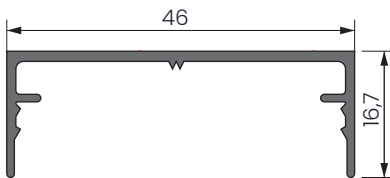

AW 5478

Tapa. 0,317 Kg/m.
Largo 6,03m

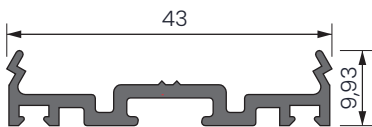

AW 5479

Soporte de tapa. 0,342Kg/m.
Largo 6,03m

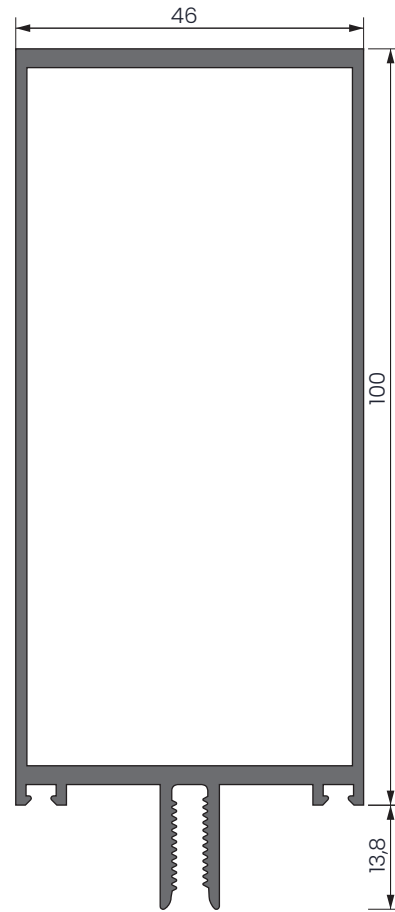

AW 5476

Columna de 100mm
1,554Kg/m. Largo 6,03m

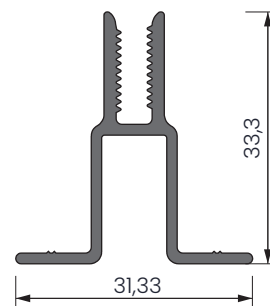

AW 5997

Adaptador DVH. 0,388Kg/m.
Largo 6,03m

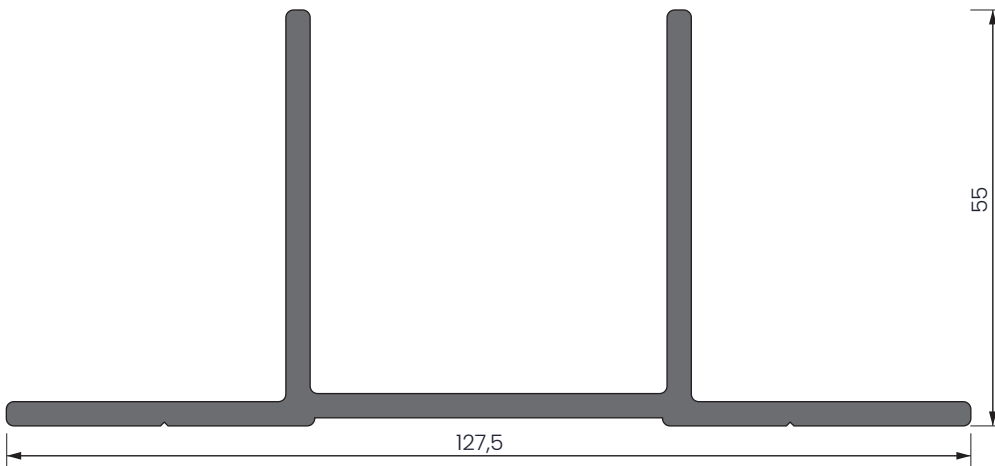

AW 5995

Soporte frente a losa SLIM.
1,998Kg/m. Largo 6,03m

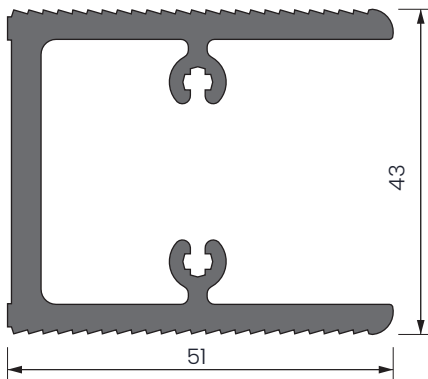

AW 5996

Escuadra SLIM. 1,558Kg/m.
Largo 6,03m

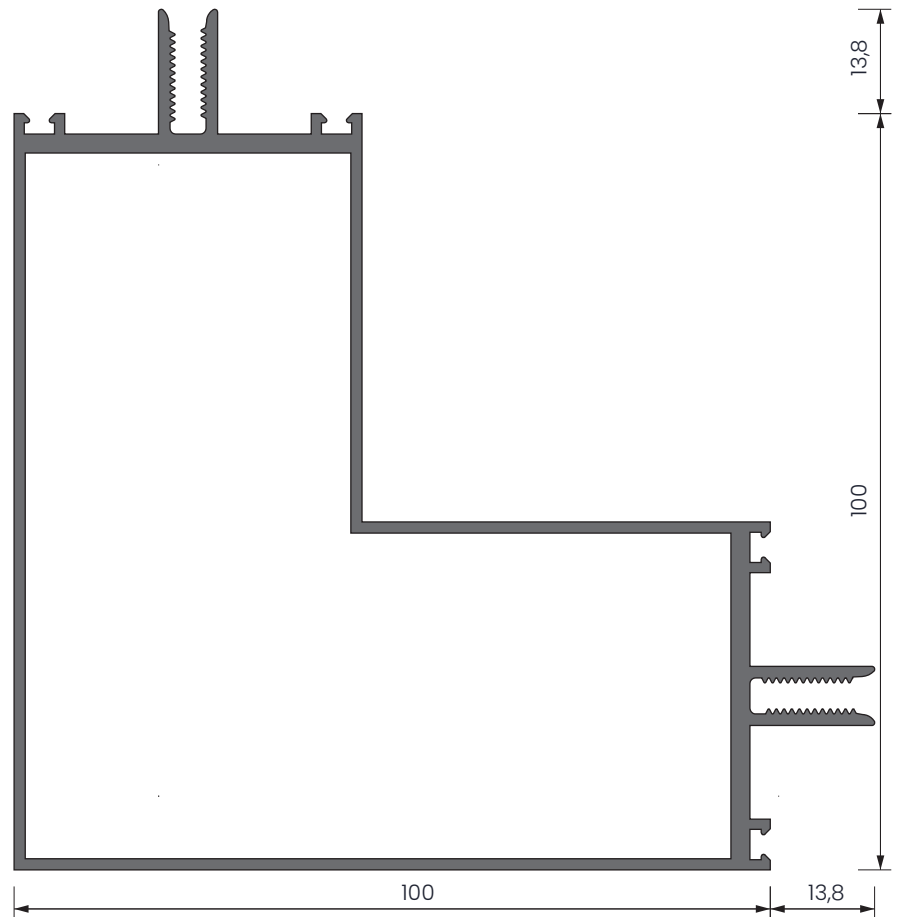

AW 5480

Columna de esquina a 90°
2,161Kg/m. Largo 6,03m

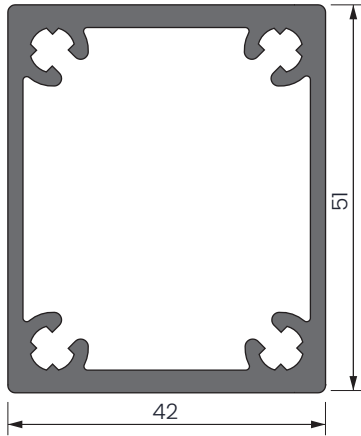

AW 5481

Refuerzo interno.
1,457 Kg/m. Largo

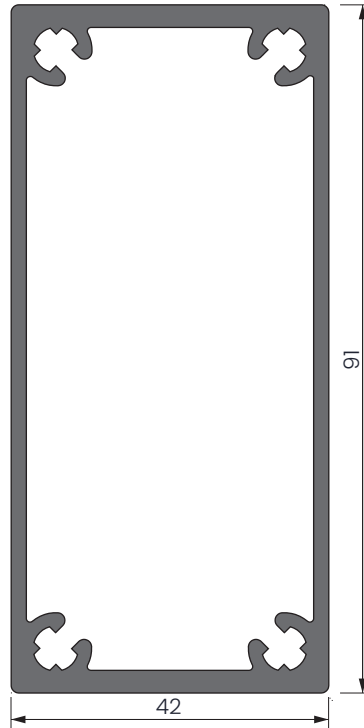

AW 5482

Refuerzo interno.
1,889 Kg/m. Largo

ACCESORIOS STANDARD

DESCRIPCION	APLICACION	IMAGEN
<p>Anclaje para frente a losa SLIM</p> <p>FIS1</p>		<p>ALUWIND PEDIDOS WEB!</p>
<p>Burlete de acristalamiento COD. B37</p>		
<p>Escuadra de armado</p> <p>FIS2 Para columna de 60mm (AW 5474).</p> <p>FIS3 Para columna de 100mm (AW 5476).</p>		<p>ALUWIND PEDIDOS WEB!</p>

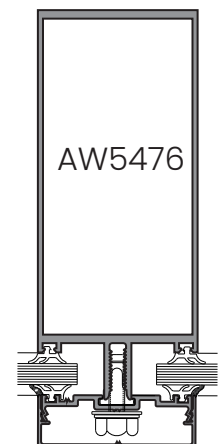
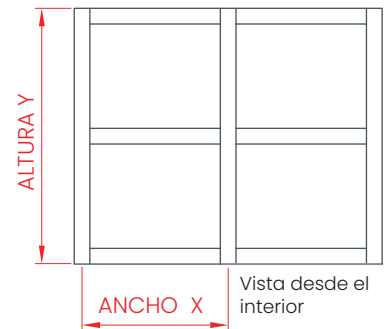
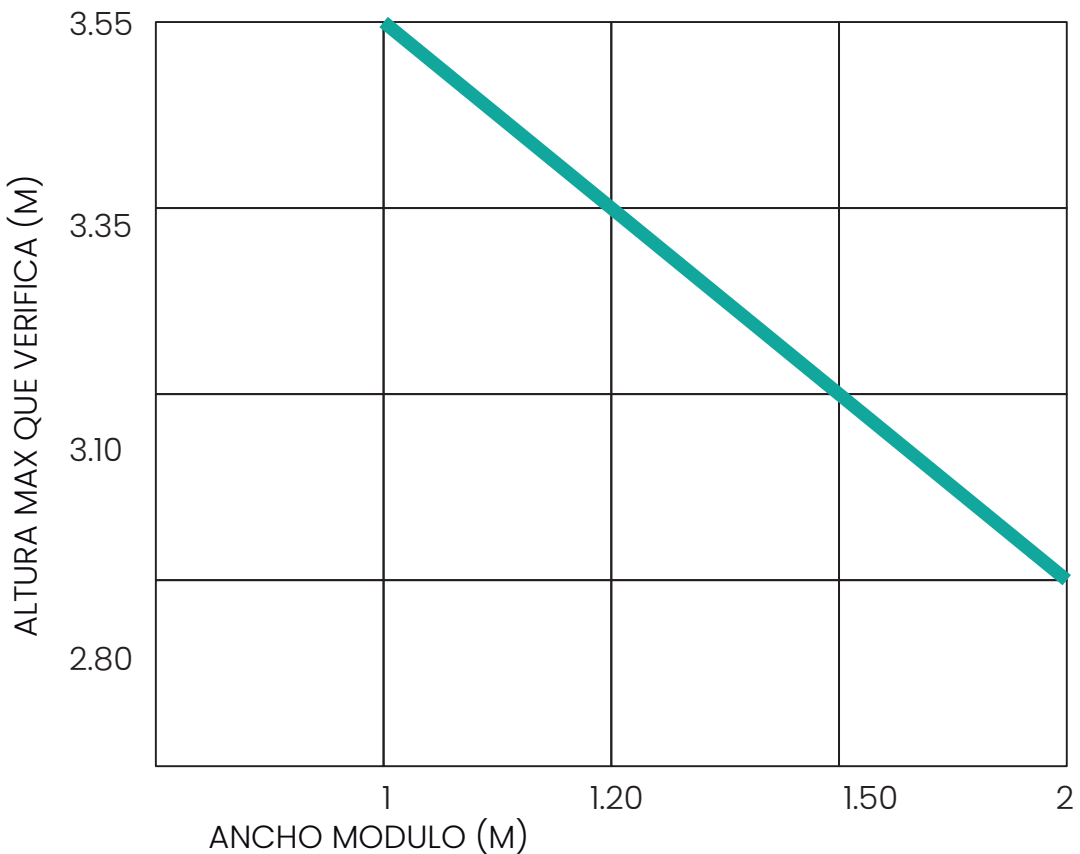
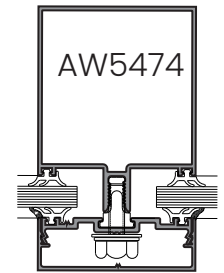
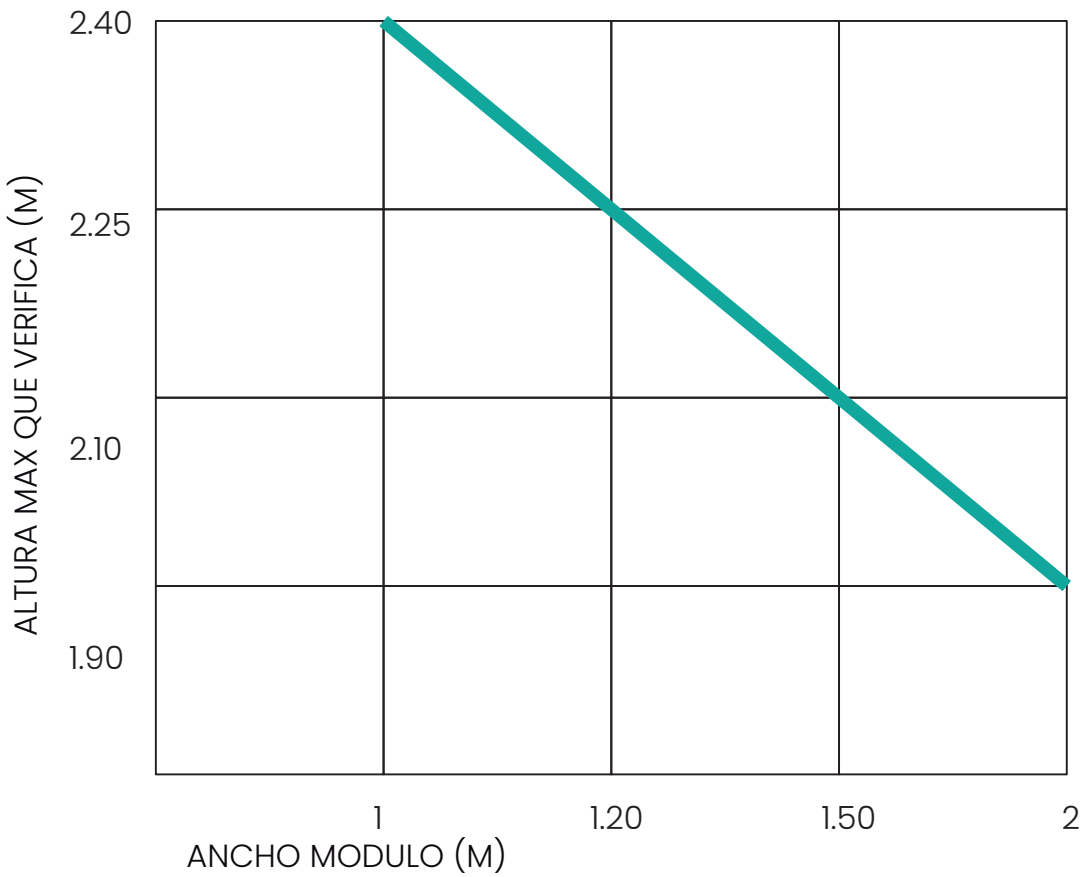

***Con el refuerzo de aluminio se incrementa la resistencia un 30%**

Detalle Vidrio simple

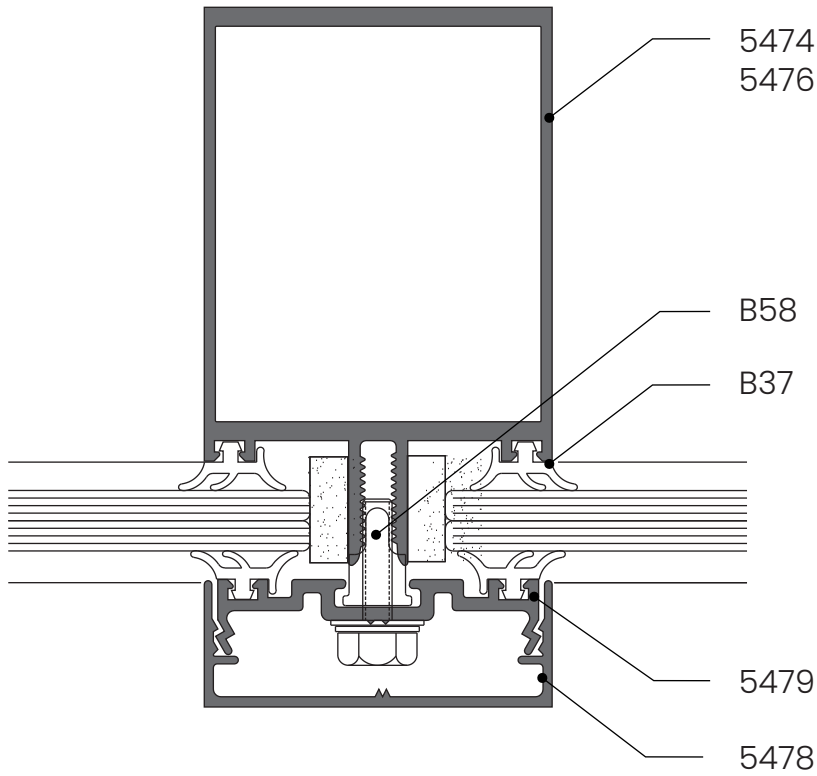

Detalle DVH

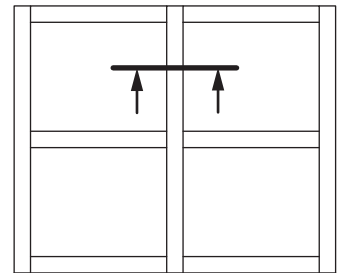
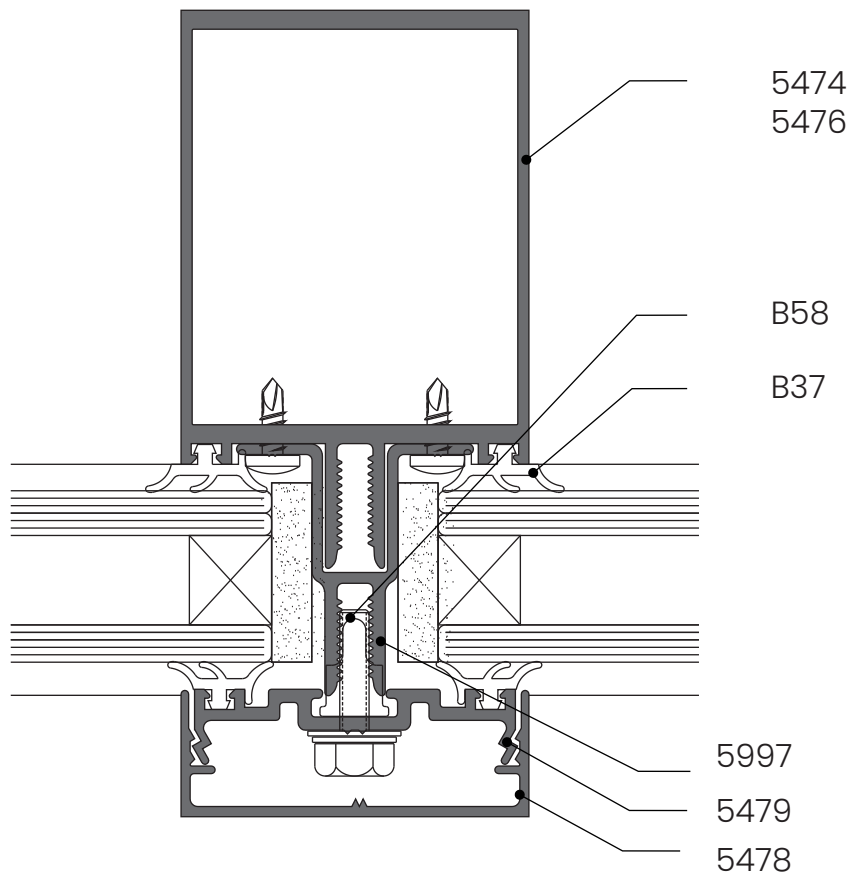

Detalle cierre con columna

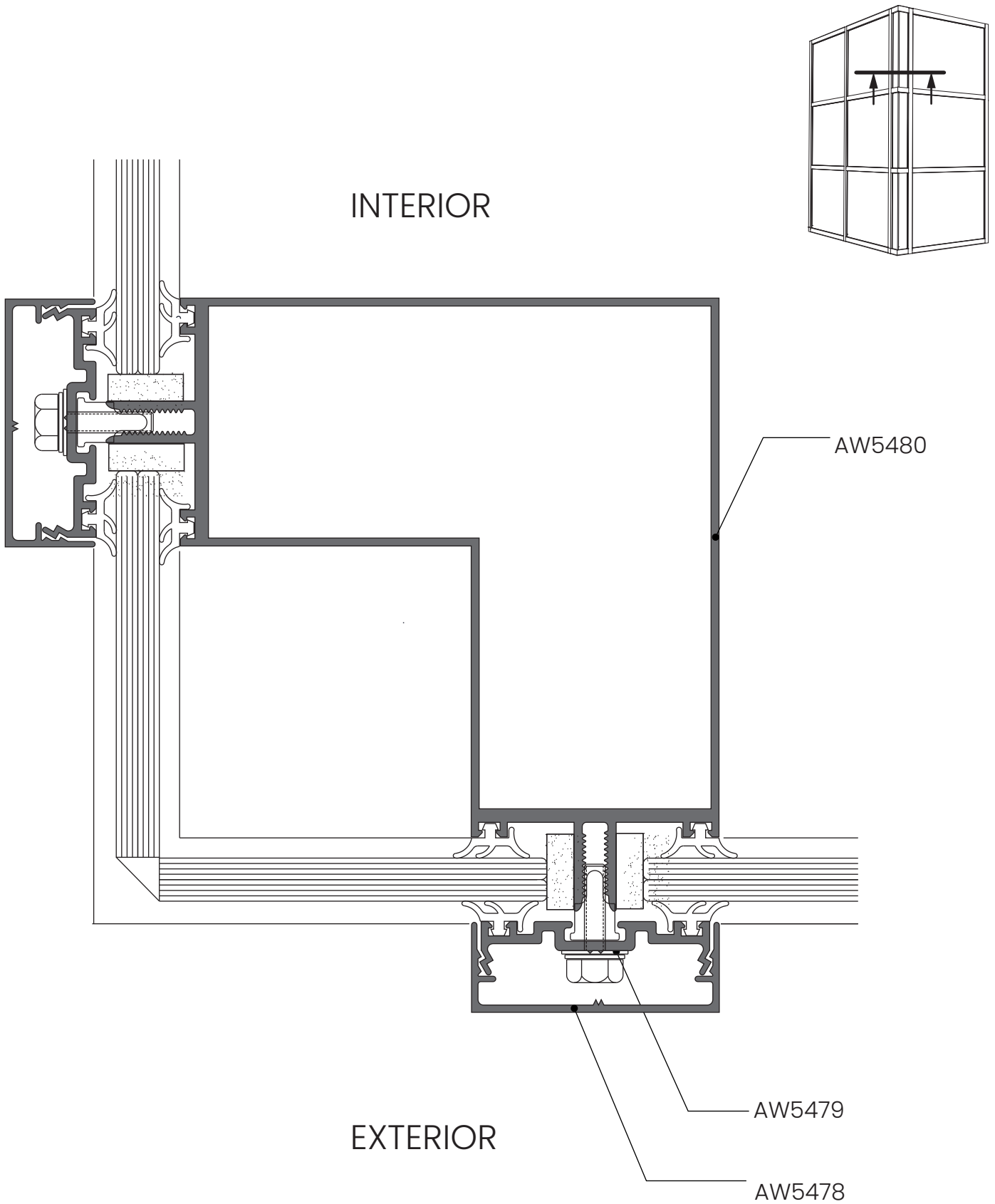

Detalle refuerzos internos

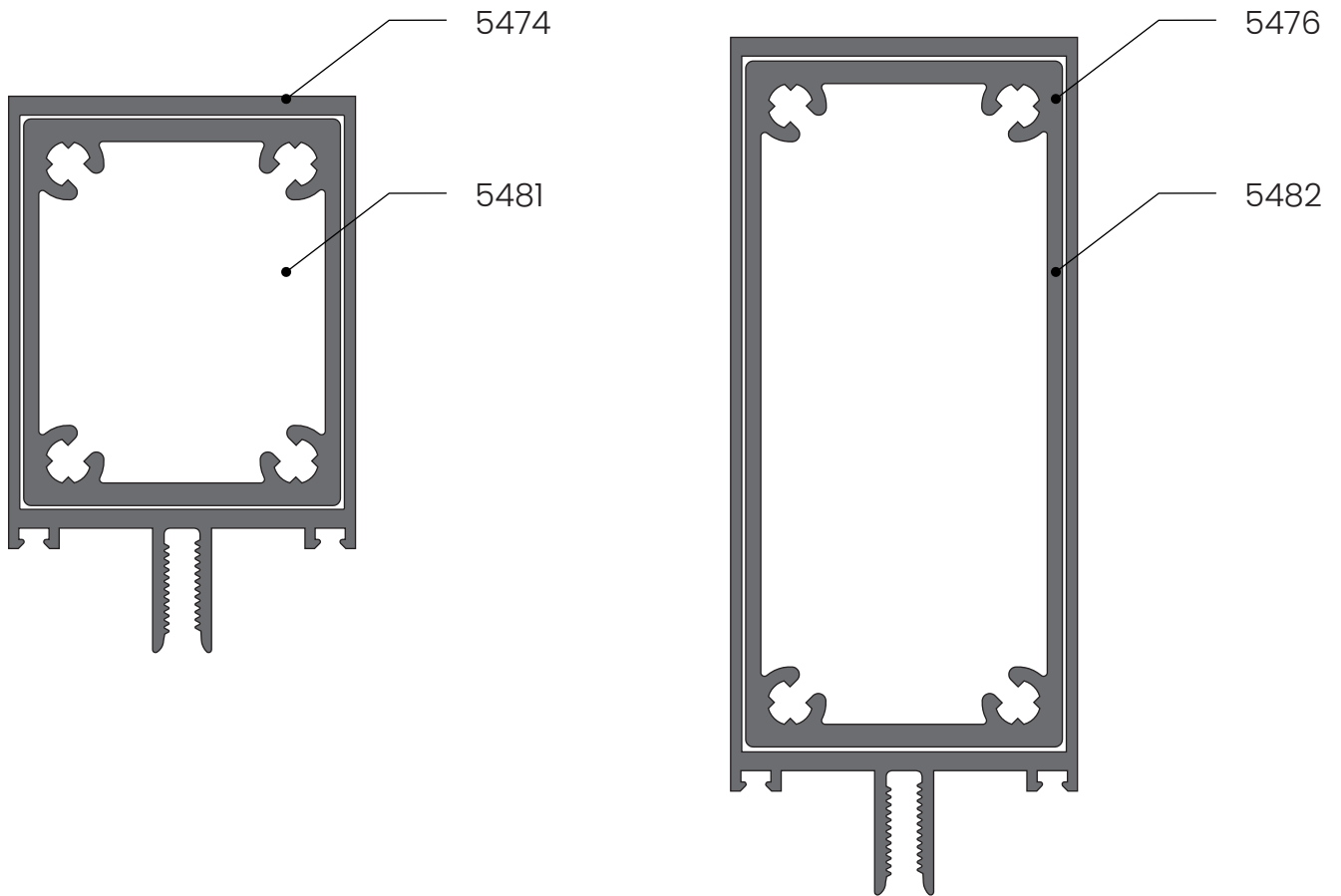

*Con el refuerzo de aluminio se incrementa la resistencia un 30%

Detalle con soporte frente a losa

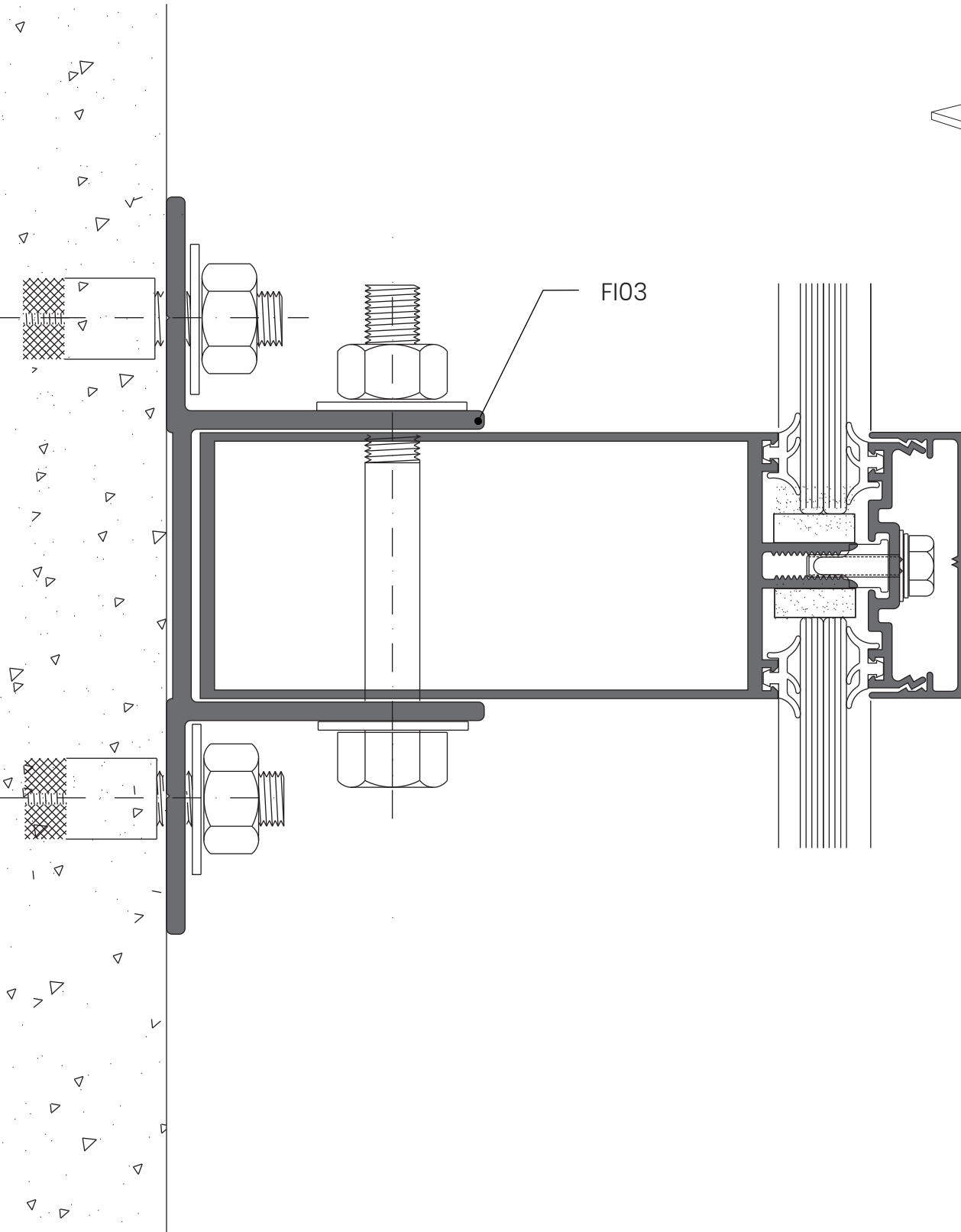
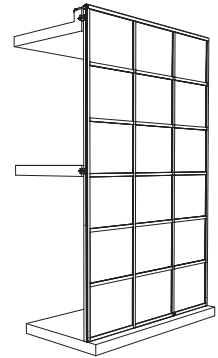

Detalle con puerta de rebatir Imperia

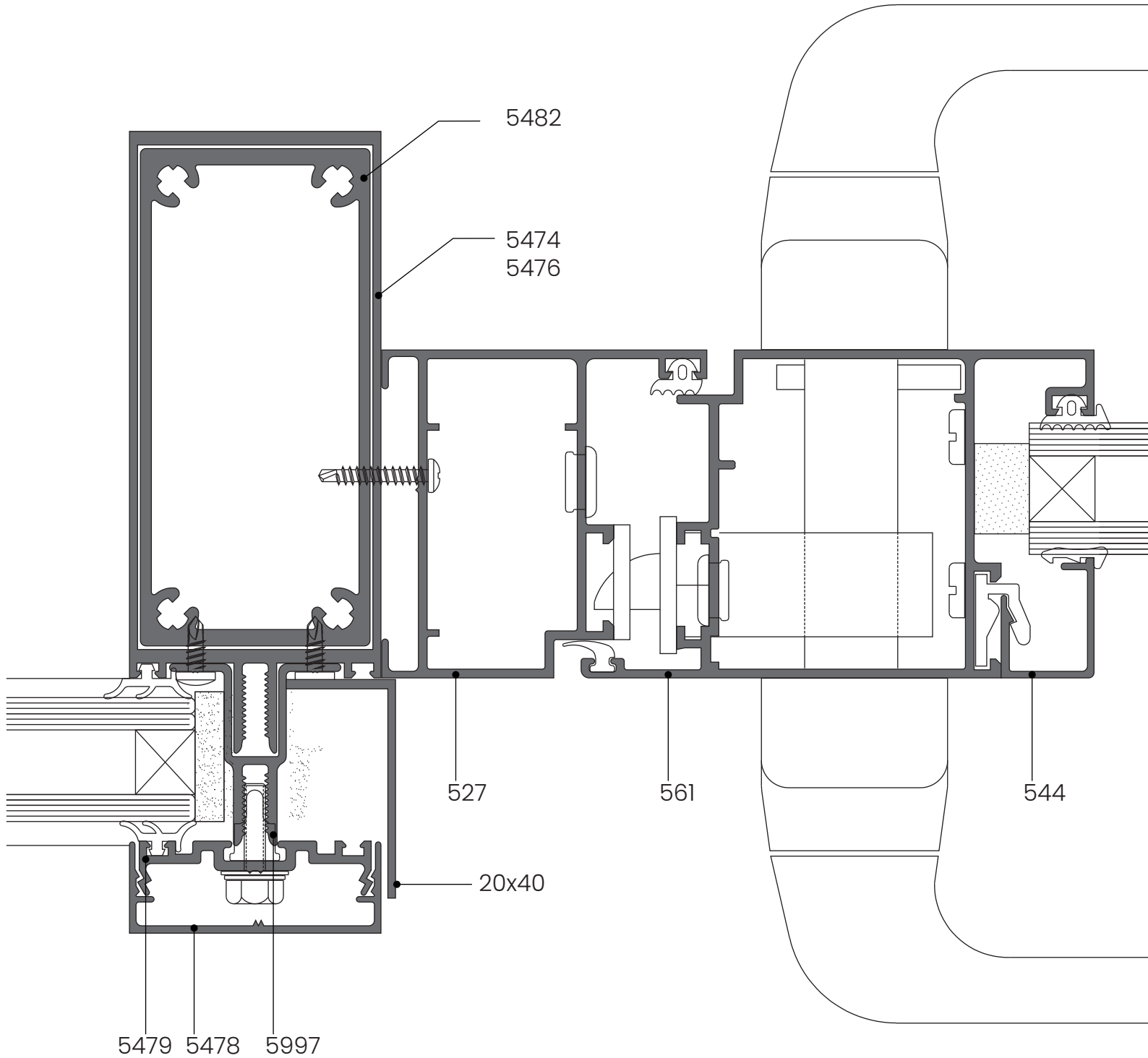

Detalle con ventana desplazable

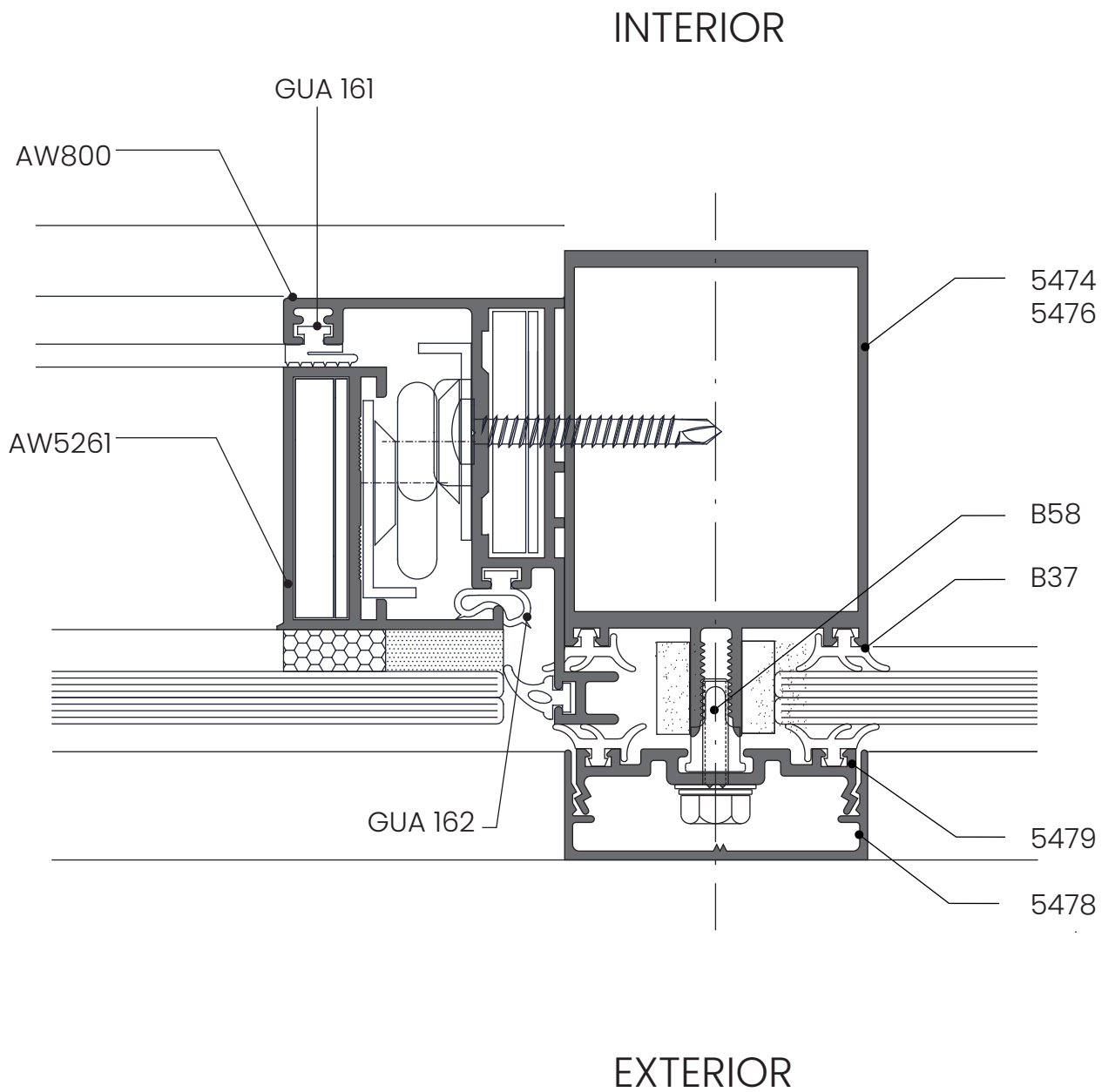

Detalle de ensamble con Sistema Ecowind

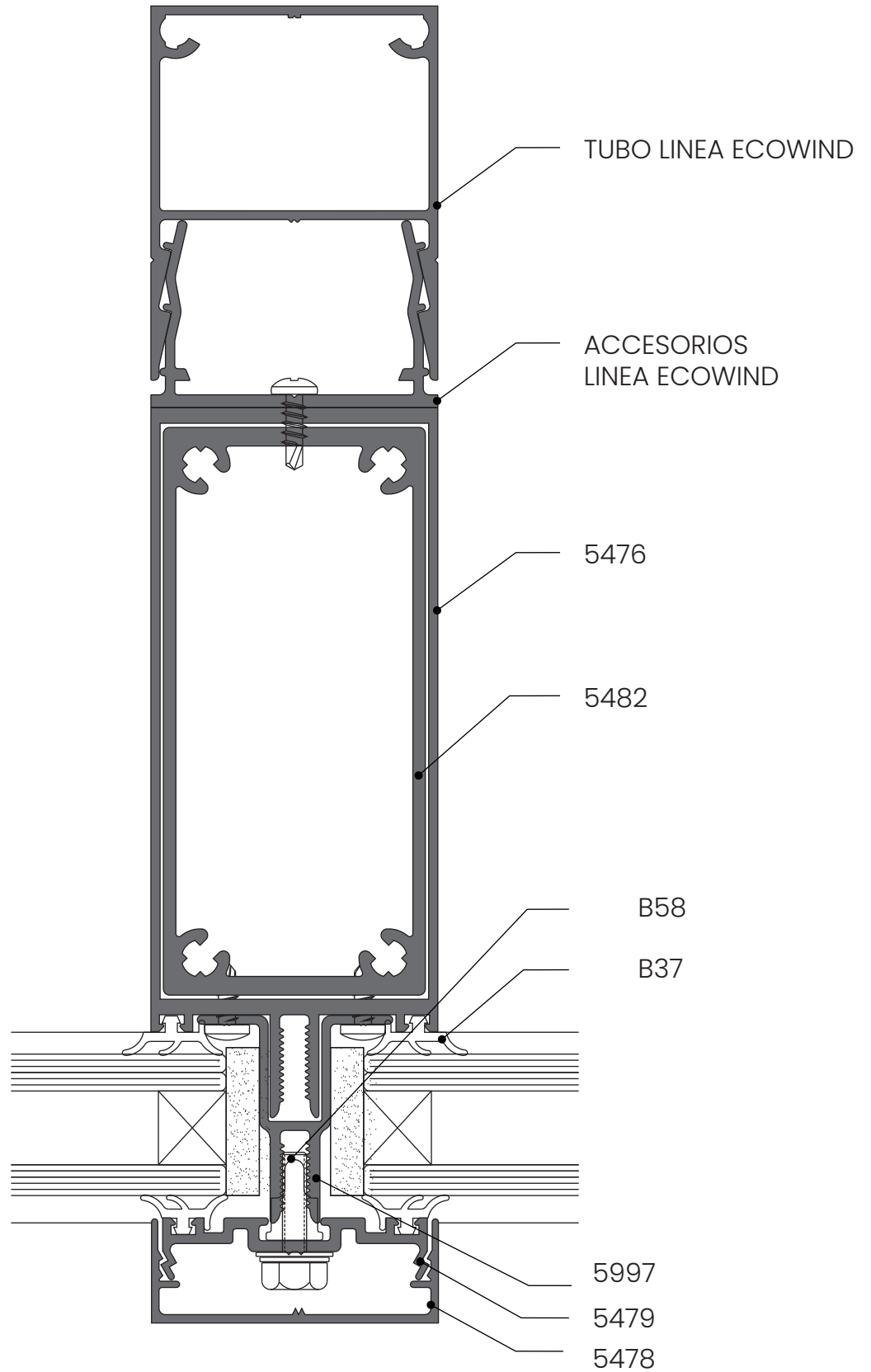

Problemas frecuentes y sus causas

Inestabilidad Mecánica en la Fachada o ruidos

- Sobrecarga
- Inercia de perfiles elegidos inferior a la necesaria
- Sobredimensión en distancia entre fijaciones mecánicas
- Anclajes y/o perfiles estructurales mal calculados o mal colocados

Falta de planimetría en los vidrios

- Faltan calzos de acristalamiento o se emplearon calzos inadecuados.
- Holguras perimetrales insuficientes entre vidrios y perfiles

Deformaciones permanentes en los perfiles

- Falta de aplomo, alineación o escuadra en las columnas
- Inercia de perfiles elegidos inferior a la necesaria
- Golpes en la manipulación o transporte
- Fallas en el cálculo estructural

Rayas, manchas o pérdida de brillo en perfiles

- Limpieza con productos abrasivos o chorro de agua a presión
- Falta de limpieza en ambientes agresivos
- Contacto con cemento o mortero durante la instalación

Roturas de vidrios

- Falta de aplomo, alineación o escuadra en las columnas
- Impactos accidentales
- Stress térmico
- Cantos de los vidrios sin pulir (existencia de micro fisuras)
- Acristalamiento sin calzos
- Por templado de vidrio
- Holguras perimetrales insuficientes entre vidrios y perfiles
- Vidrio aislante con columnas mal escuadradas



 Av. Japón 550 - Córdoba, Argentina - CP 5019

 comercial2.aluwind@gmail.com

 (0351) 499 5597 / 499 8915

 +54 9 351 695 7920

 www.aluwind.com.ar

  /AluwindSA